

ADA
M
5000

PC-based Solution for Distributed Data Acquisition & Control



Outline

 **New Product Announcement**
--- **ADAM-5000/RS-485**

 **Ongoing ADAM-5000 CAN Bus**
Version

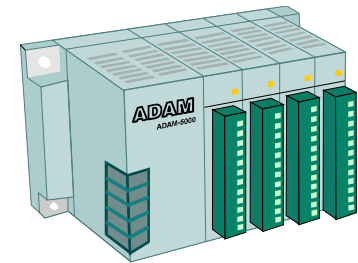

ADVANTECH.

ADA
M
5000

Successful Sales on ADAM-4000



Easy to Use

 2-wire RS-485 Networking

 Programming Via ASCII
Command

 Programmable Input Ranges

 DIN-Rail/Panel Mounting

 Plug-in I/O Terminal Block

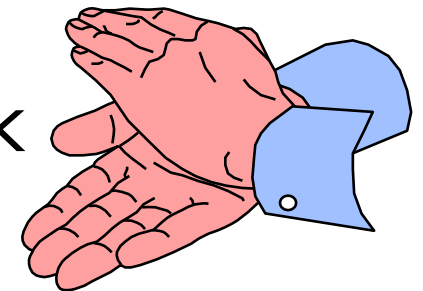

ADVANTECH.

**ADA
M
5000**

Why Design ADAM-5000 ?

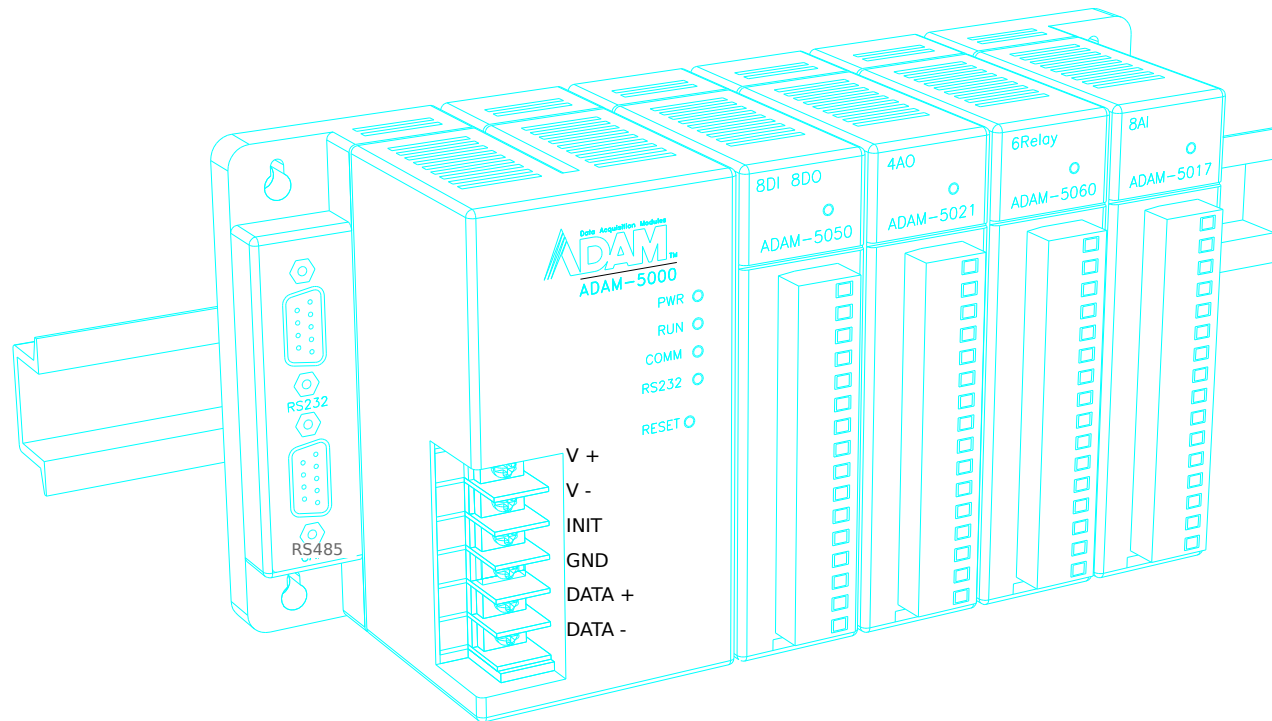

ADVANTECH.

From Customers Feedback

- Multi-channel Solution
- Faster Communication Speed
- Watchdog Supervisory
- 3-way Isolation
- Event Handling Capability
- Remote Download Program
- Multiple Communication Protocol Support



**ADA
M
5000**

Advantech Remote DA&C Solution Road Map

Product
Solution

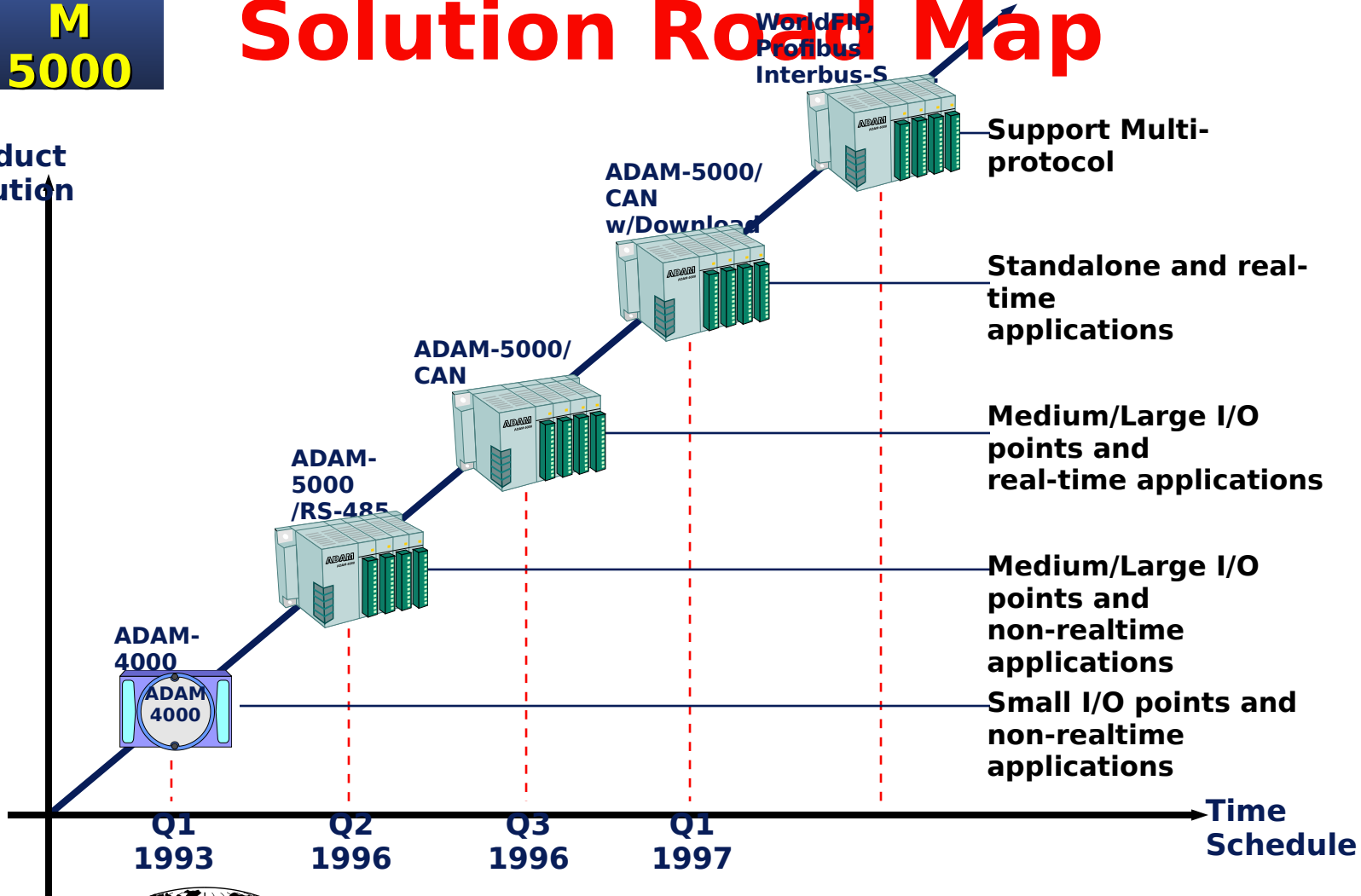

ADVANTECH.

**ADA
M
5000**

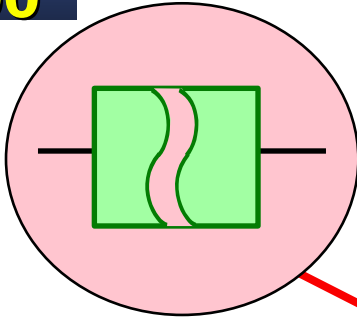

3-way
Isolation

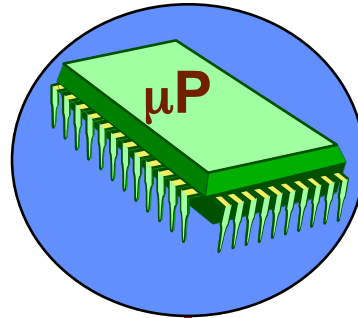

Upgradable
CPU
Modules

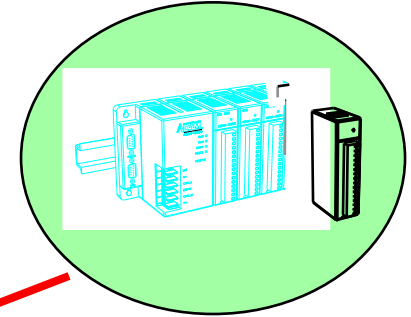

Flexible Multi-
channel
Solution

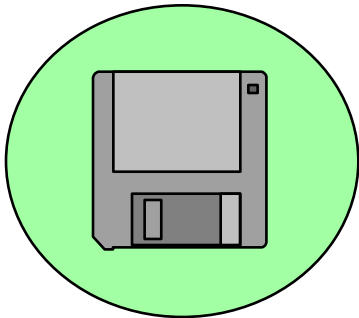
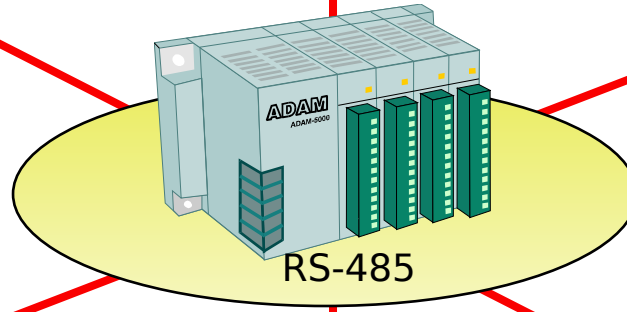

Programmable I/O
Range

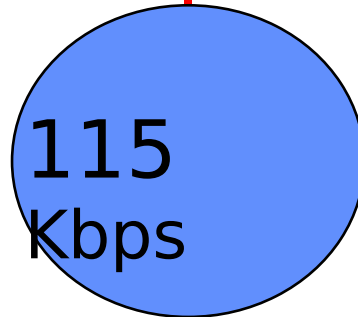

Faster
Communication
Speed

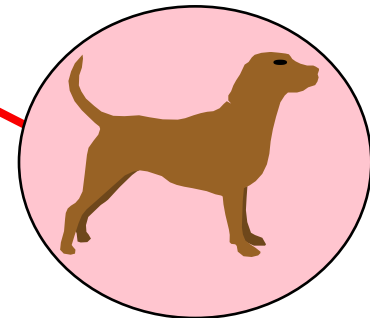

Watchdog
Timer



ADVANTECH.

**ADA
M
5000**

Flexible Multi-channel Solutions

- Up to 32 AIO or 64 DIO per Node
- Flexible I/O Combination and Alarm Setting

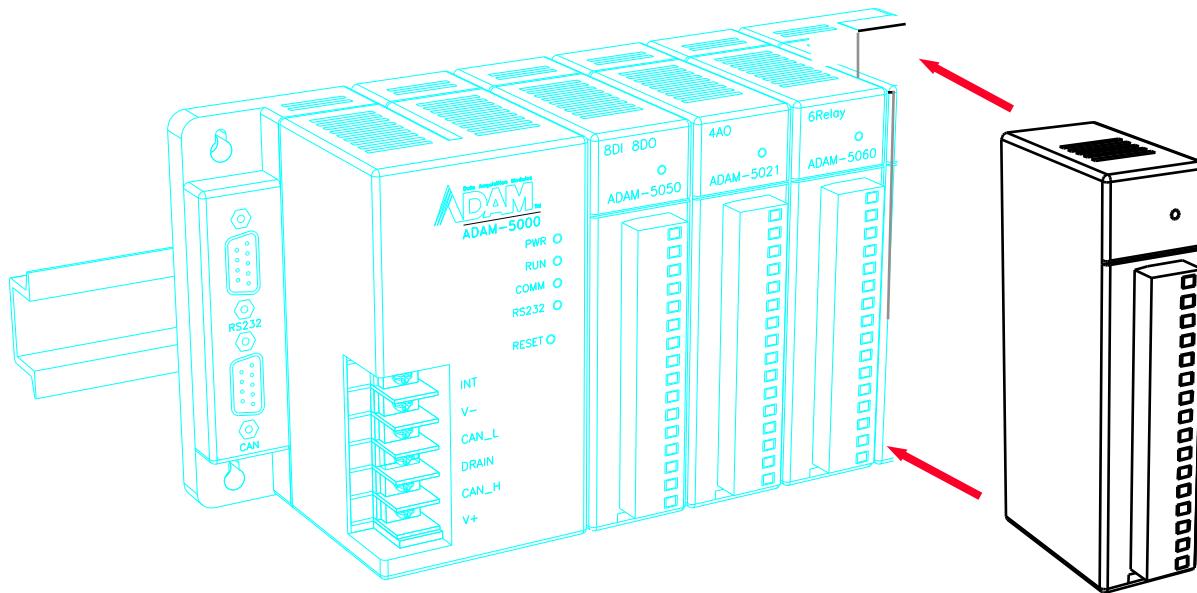

ADVANTECH.

ADA
M
5000

Watchdog Supervisory

 Auto Reset ADAM-5000
Microprocessor
After System Failure

 Reduce Maintenance Works

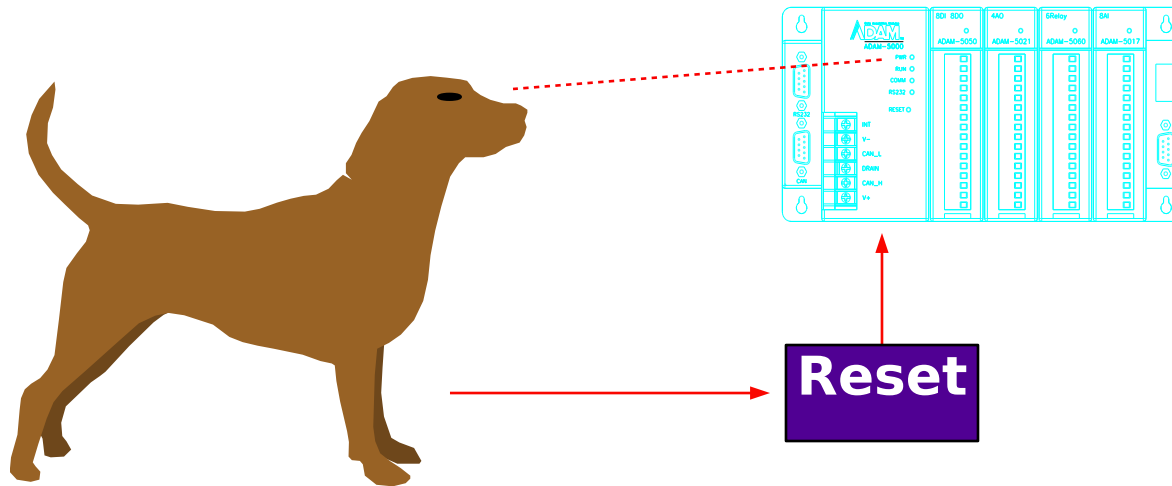

ADVANTECH.

ADA
M
5000

3-way Isolation -- I/O, Power and Communication

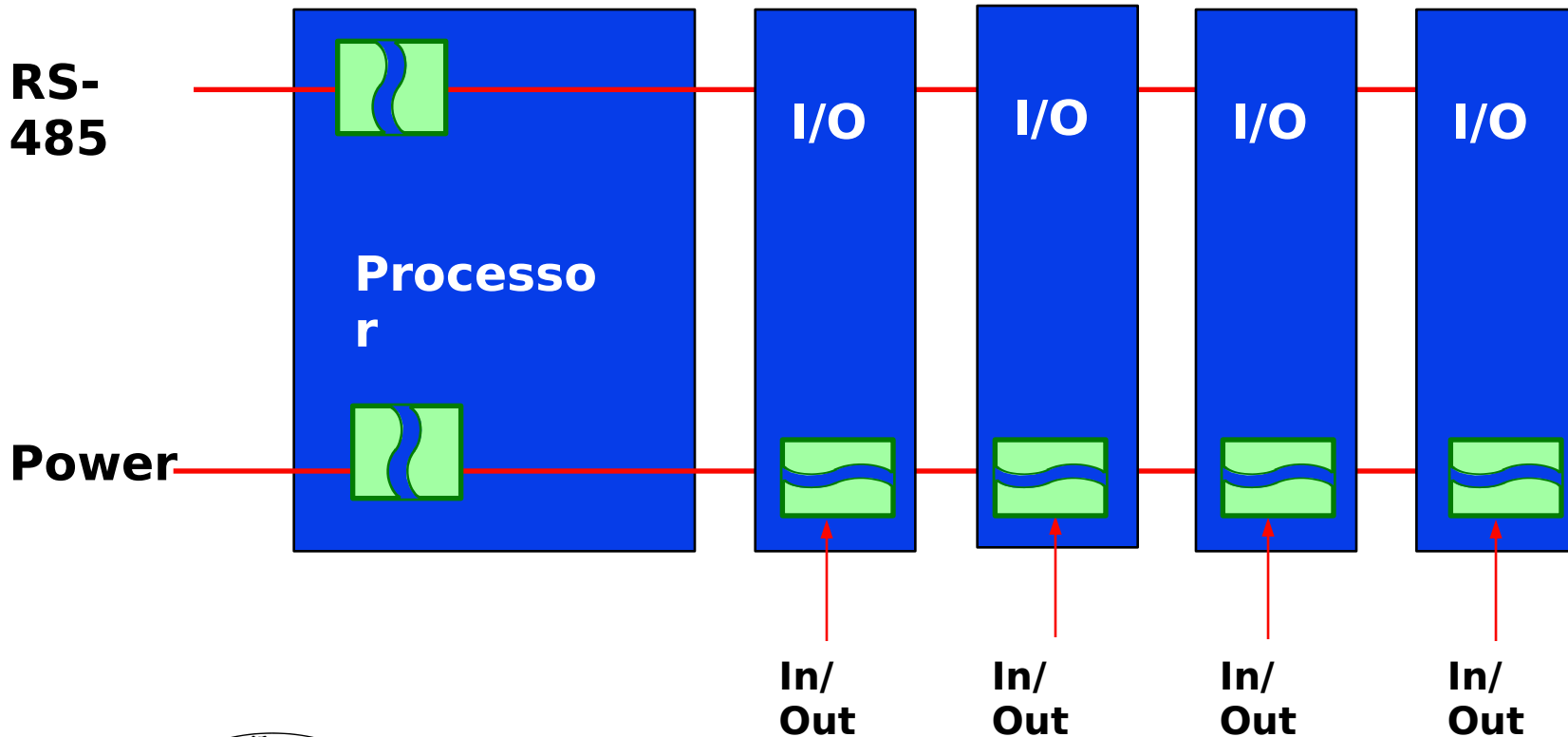

ADVANTECH.

ADA
M
5000

Faster Communication, Larger System Scale

 Communication Speed Up to 115.2
Kbps

(Scan Rate : 400 Analog
Reading/Sec.)

 Controllable Points per Serial Port :
8192



ADVANTECH.

ADA
M
5000

Programmable Input/Output Type and Ranges

 No Pots, No Switches to Set

 Reducing Your Stock

15mV
50mV
100mV
500mV
1V
2.5V
0.20m
A
T/C.J
T/C.K
T/C.T
T/C.E
T/C.R
T/C.S
T/C.B

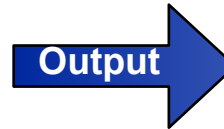
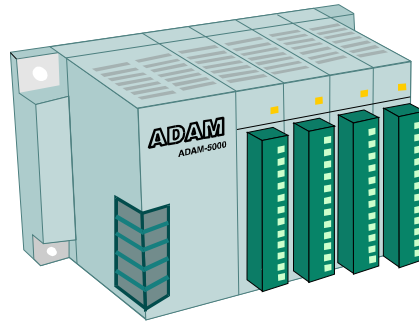
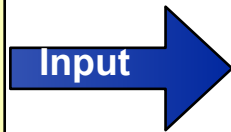

23.5
Engineering
Unit
33.20
% of
FSR
7FF
Twos
Complement



ADVANTECH.

ADA
M
5000

ADAM-5000/485 Upgradable CPU Module

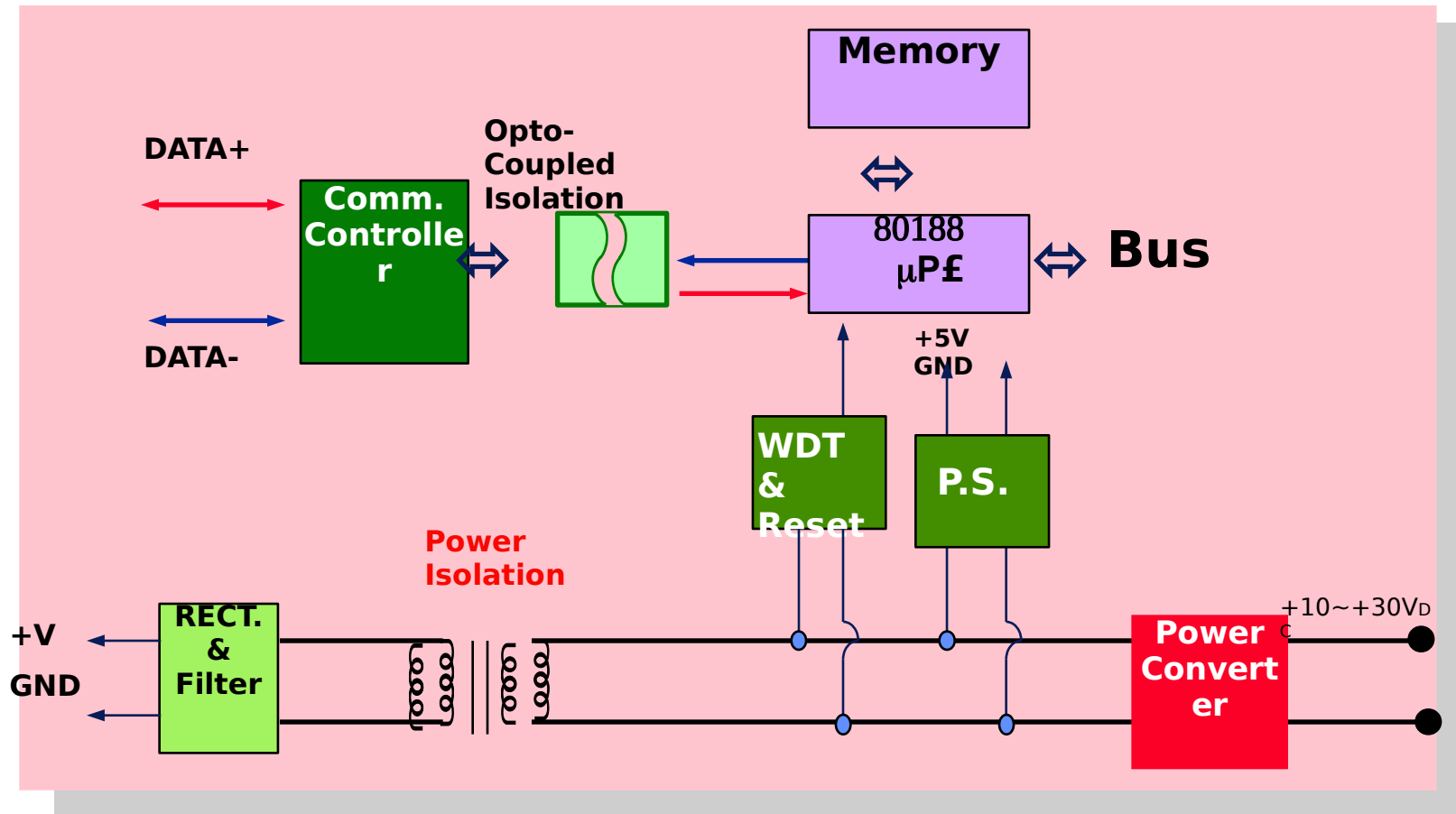

ADVANTECH.

I/O Modules

| Feature/Module | | 5017 | 5018 | 5024 | 5050 | 5060 |
|----------------|----------------------------------|-----------------------|-----------------------|---------------------|------|---------------------|
| Analog I/O | Channels | 8 | 8 | 4 | — | — |
| | Input Types | mV, V, mA | mV, V, mA, T/C | — | — | — |
| | Sampling Rate | 10 | 10 | — | — | — |
| | Resolution | 16 bits | 16 bits | 12 bits | — | — |
| | Isolation | 1,000 V _{DC} | 1,000 V _{DC} | 500 V _{DC} | — | — |
| | Output Types | — | — | mA, V | — | — |
| | Slew Rate | — | — | Programmable | — | — |
| Digital I/O | D/I Channels (Input: 0~30V) | — | — | — | 8 | — |
| | D/O Channels (Open Collector) | — | — | — | 8 | 6 (Relay Output) |
| | Isolation | — | — | — | — | Yes |



ADA
M
5000

ADAM-5000 Mechanism -- Front Panel

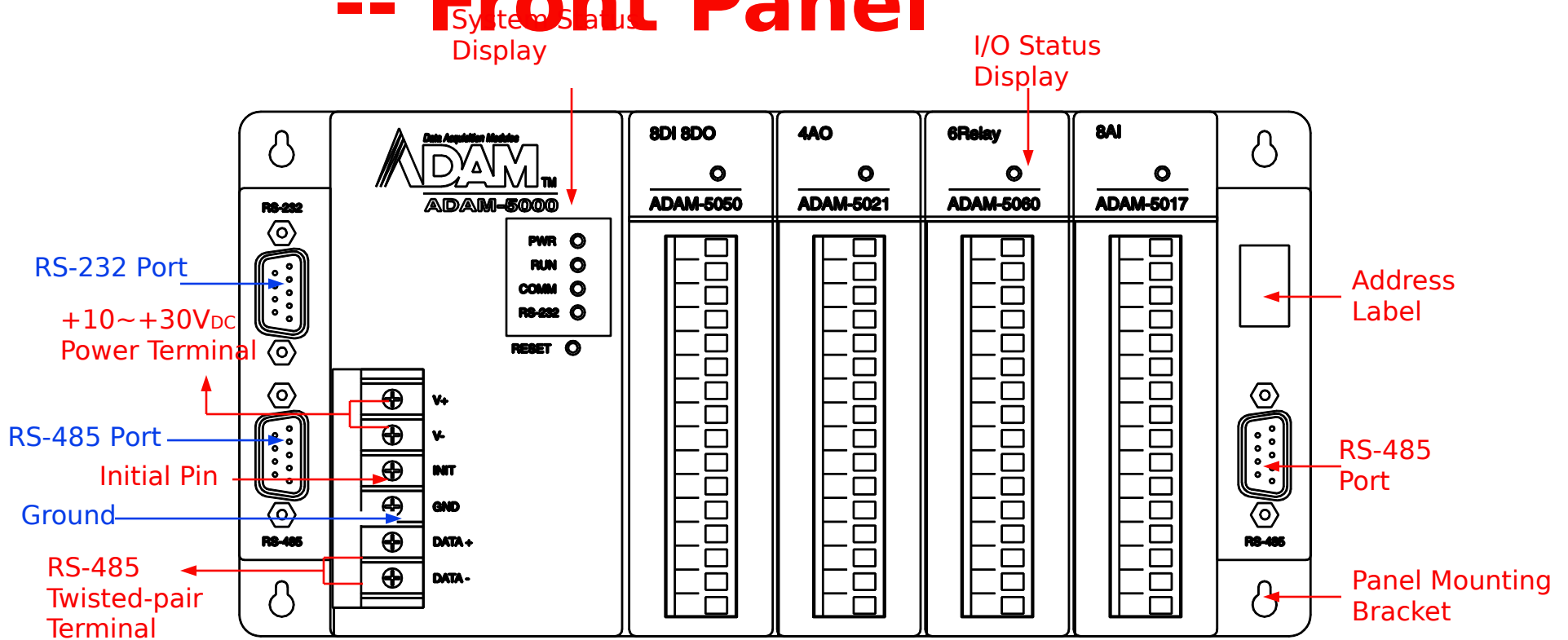

ADVANTECH.

**ADA
M
5000**

Flexible Networking

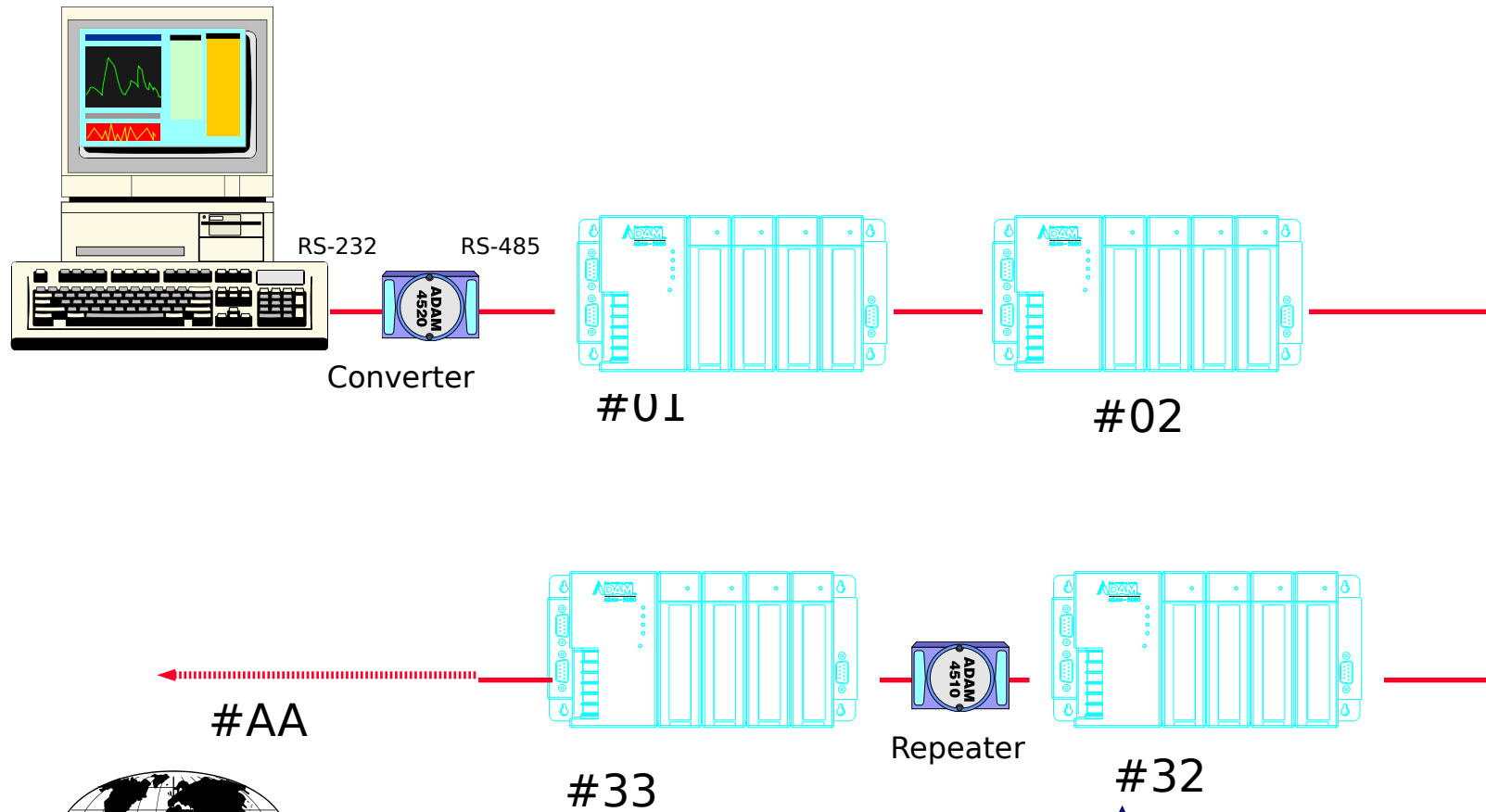

ADVANTECH.

Programming

- Simple ASCII Command
- Easy Programming and Configuration
- Support both ADAM-5000 and ADAM-4000

Protocols

Node Address Channel
↑ ↑

```
Command : #05 1  
Response :  
>+4.834
```

ADAM-
4000

Node Address Slot Channel
↑ ↑ ↑



```
Command : #05 S0  
C1  
Response :
```

ADAM-
5000



ADA
M
5000

Extensive Windows Application Support

-  DDE Server
-  DLL
-  Advantech DA&C S/W package --
Genie

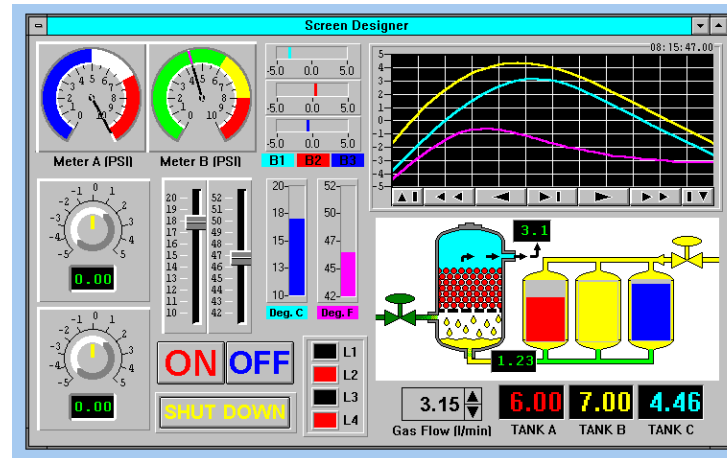

ADVANTECH.

ADA
M
5000

Welcome to CAN

Controller Area Network

 Developed by Bosch

 ISO 11898 Standard



ADVANTECH.

**ADA
M
5000**

Communication
Collision
Management

Open
Communication
Protocols

Event
Handling

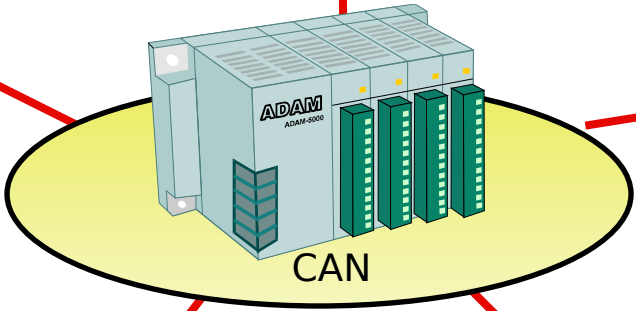

Peer-to-Peer
Communication

Error Free
Communication



**ADA
M
5000**

Event Handling

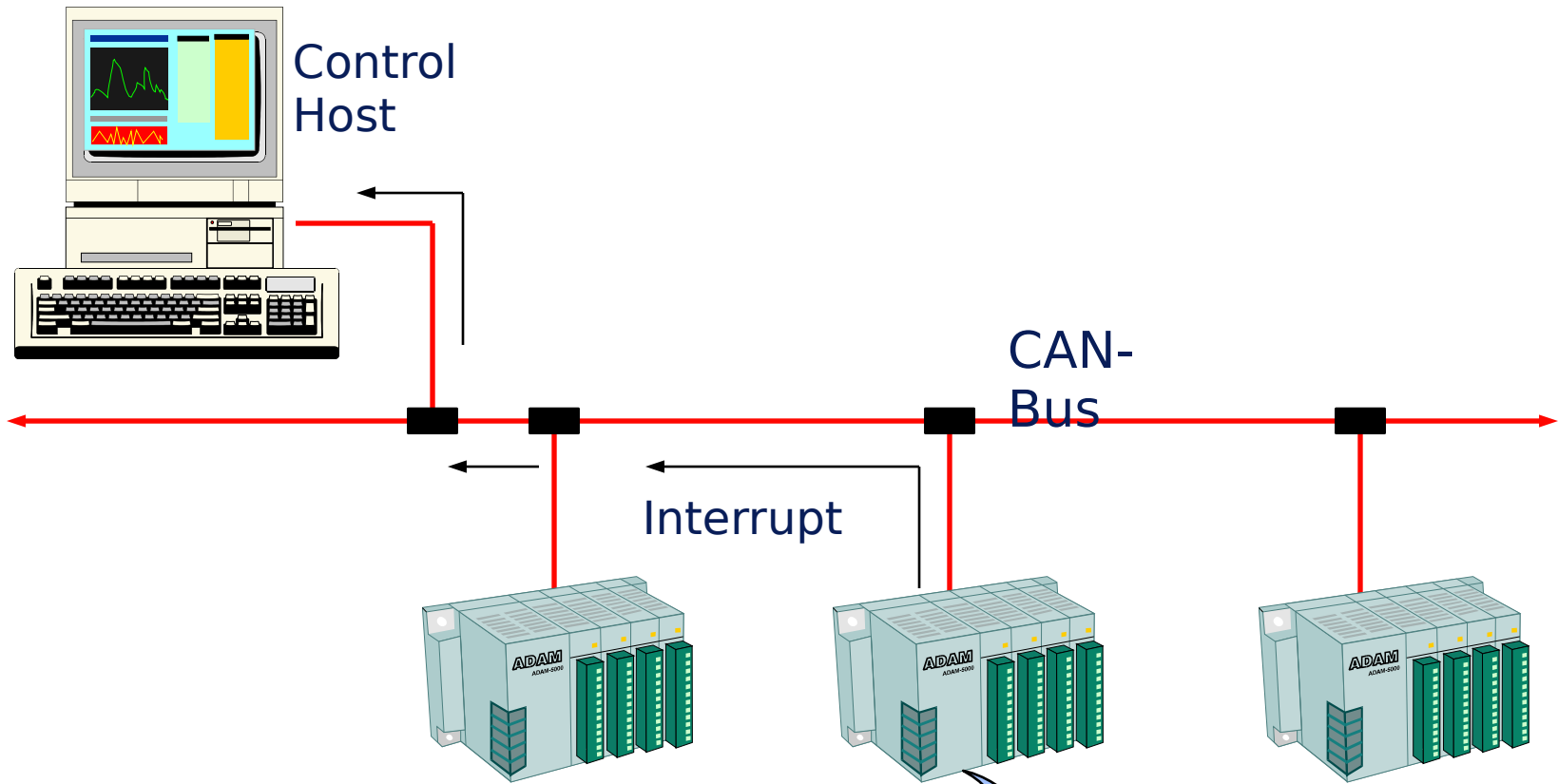

Event Happens



ADVANTECH.

ADA
M
5000

Error Free Communication

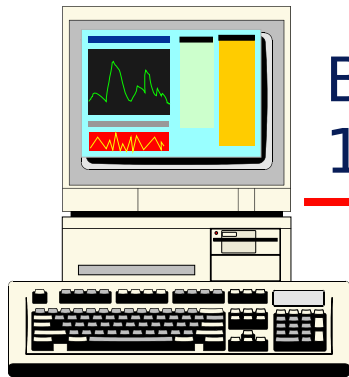

Bit Error Probability 10^{-13}

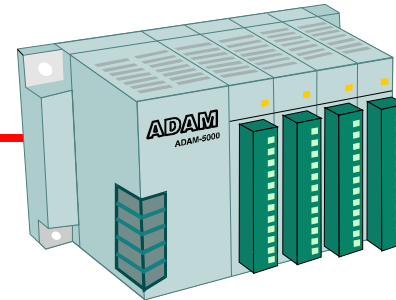

ADVANTECH.

Peer-to-Peer Communication

 Respond Only

 Automatic Report in A Fixed Period

 Automatic Report While The State Is
Changed

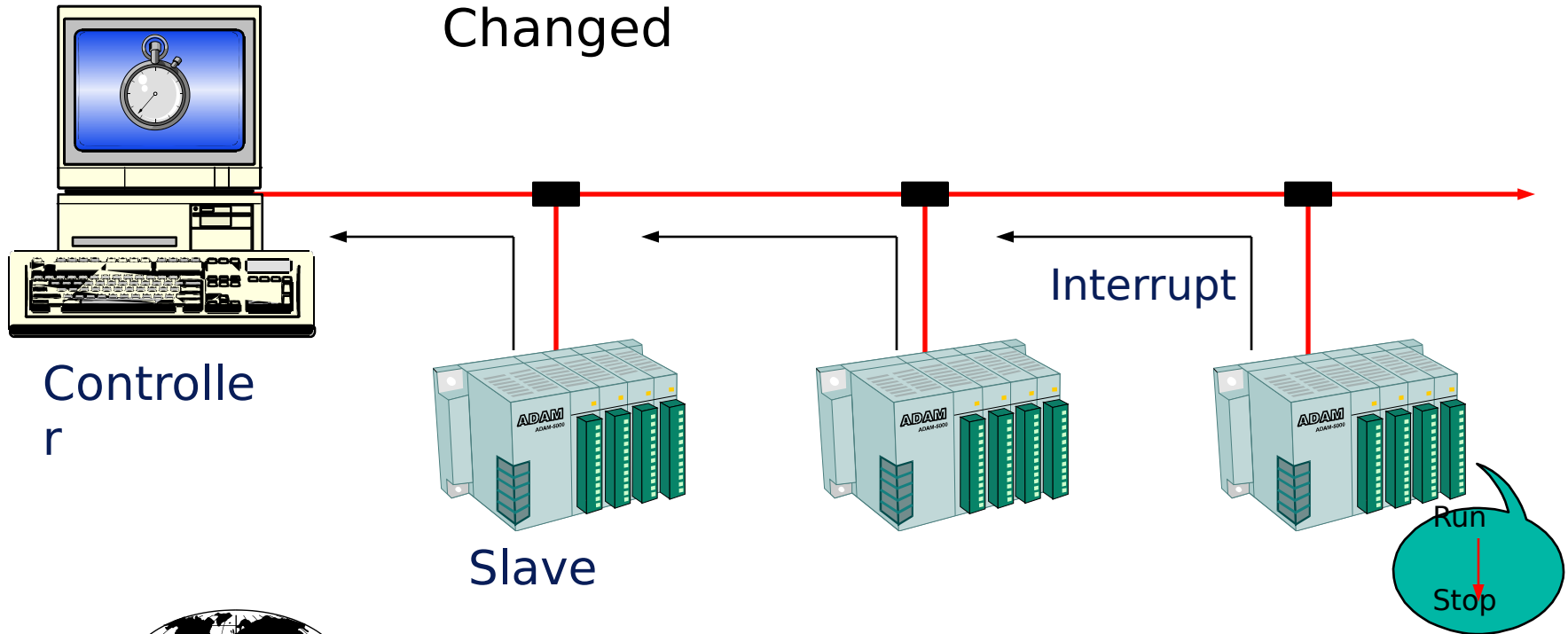

ADA
M
5000

Communication Collision Management

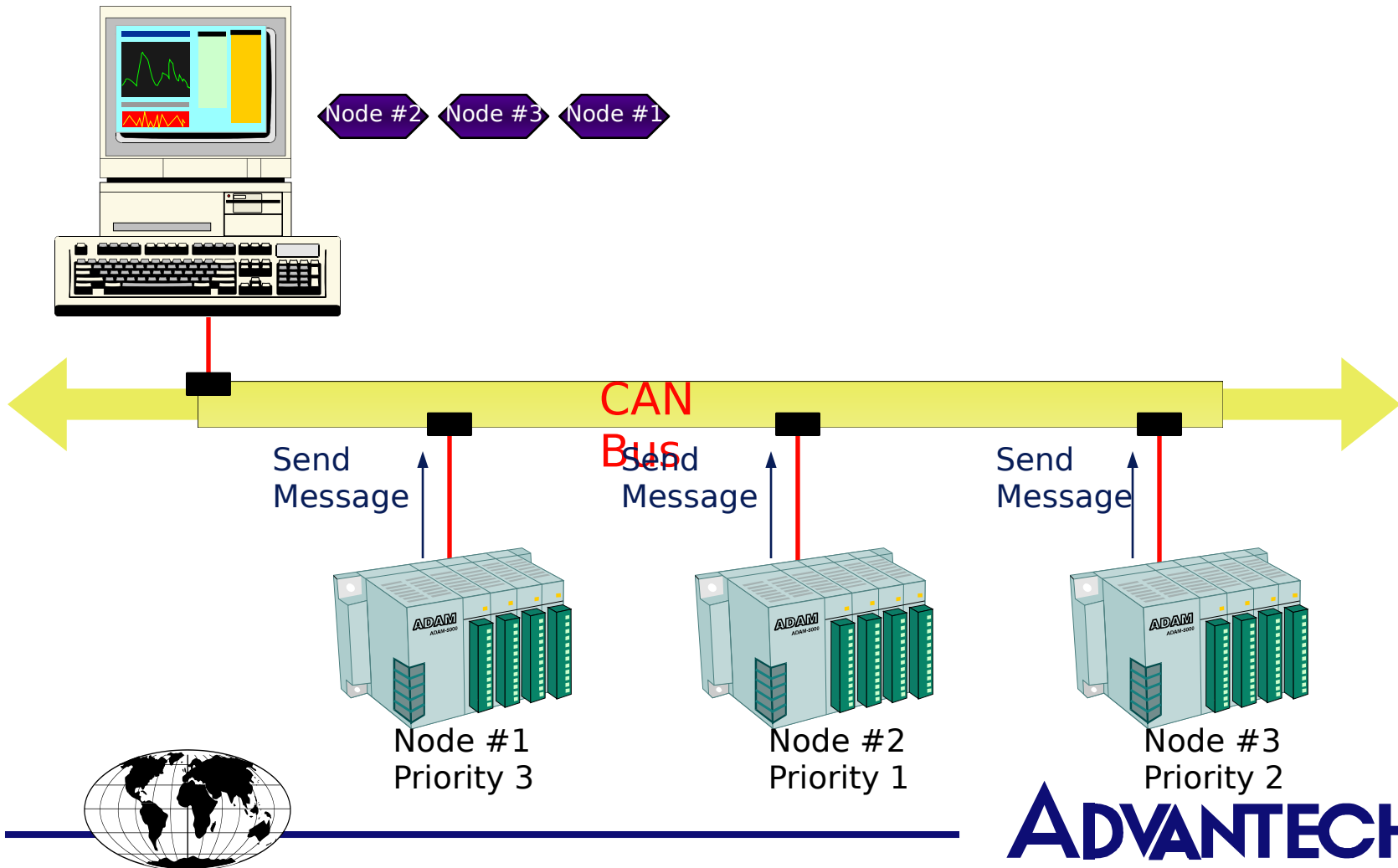

ADVANTECH.

Communication Protocol of CAN

- Media : Shield Twisted Pair, Multidrop
- Access : Master/Slave and Peer-to-Peer
- Max. Nodes Per Line : 64
- Speed Dependent on Overall Length
 - 125 Kbps @500m/1600ft
 - 250 Kbps @200m/600ft
 - 500 Kbps @100m/300ft
- Data IDENTIFIER -- 11bits with Priorities
- Five Communication Error Detection Mechanisms



Open Communication Protocols

-  DeviceNet
-  SDS (Smart Distributed System)
-  CiA (CAN International Association)

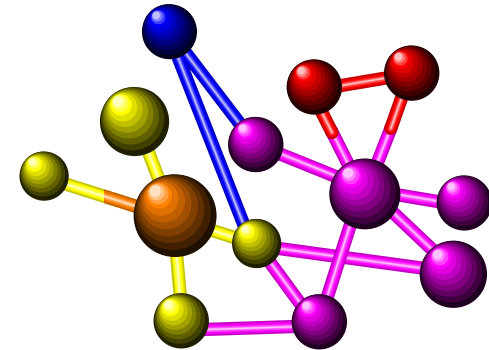

Why Choose DeviceNet First?

 DeviceNet is # 1 in U.S. Market
Study of Sensor/Device Level Bus

 Over 100 Companies Join ODVA (Open DeviceNet

Vendors Association) --- Allen-Bradley ,
Advantech, Belden
Wire & Cable, Phoenix, Wago, OMRON, Clutter-
Hammer, Yaskawa
Electric, ABB, T... Underware,
Intellution,
etc.

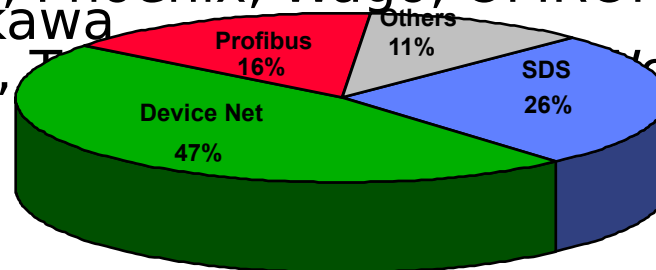

Source : Instrumentation and
Control
OEMs Surveyed, spring 1995



S/W Support

- DeviceNet Function Library
- DDE & DLL for Windows Application
- Genie

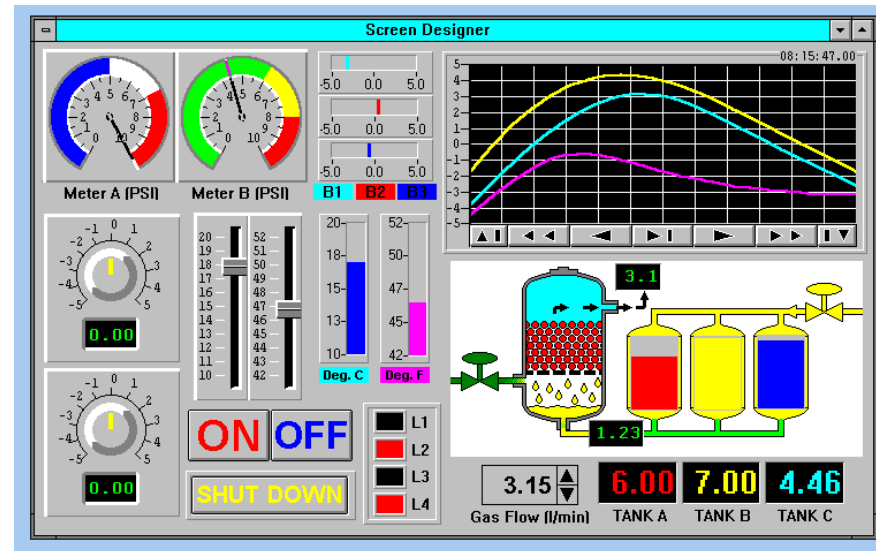

ADA
M
5000

ADAM-5000 CAN Version -- Front Panel

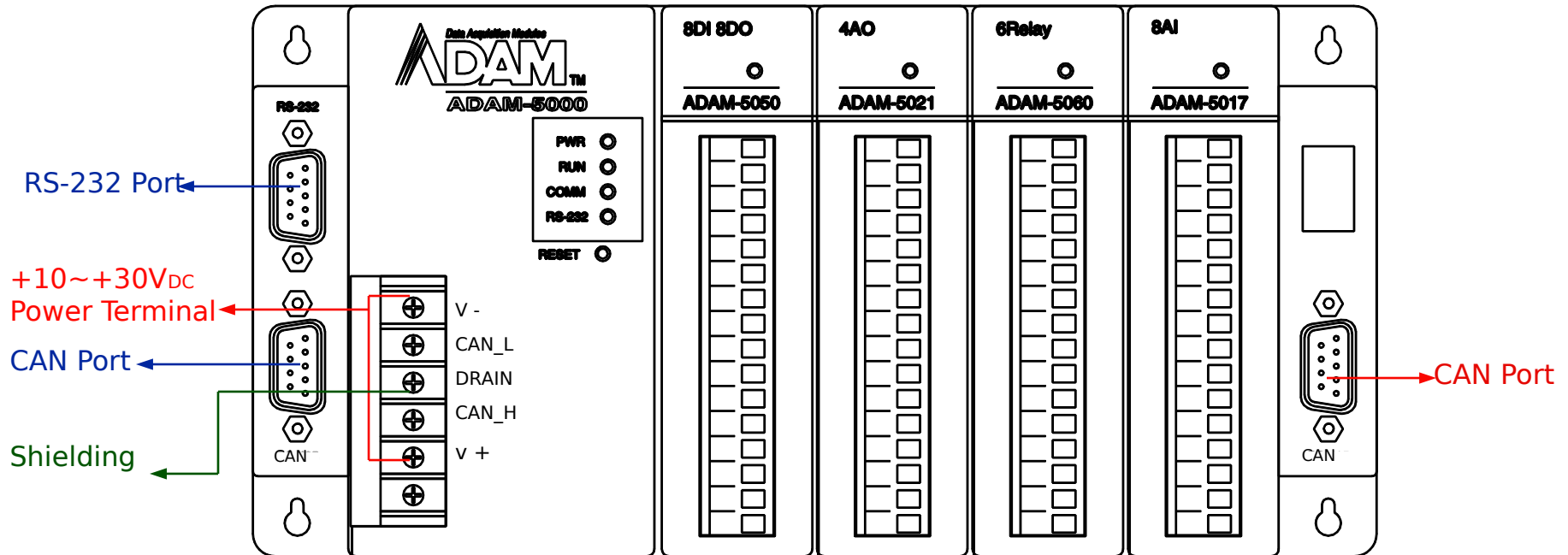

ADVANTECH.

ADA
M
5000

ADAM-5000 -----

- Provides Cost-effective Multi-channel Solutions for Industrial Automation
- Meets the Needs of Different Applications from Non-realtime to Realtime

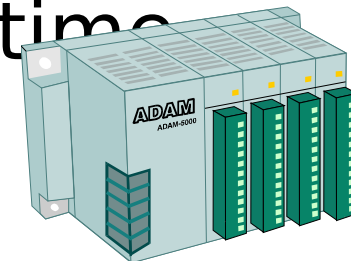

ADVANTECH.

**ADA
M
5000**

ADAM-5000 Products Shipment Schedule

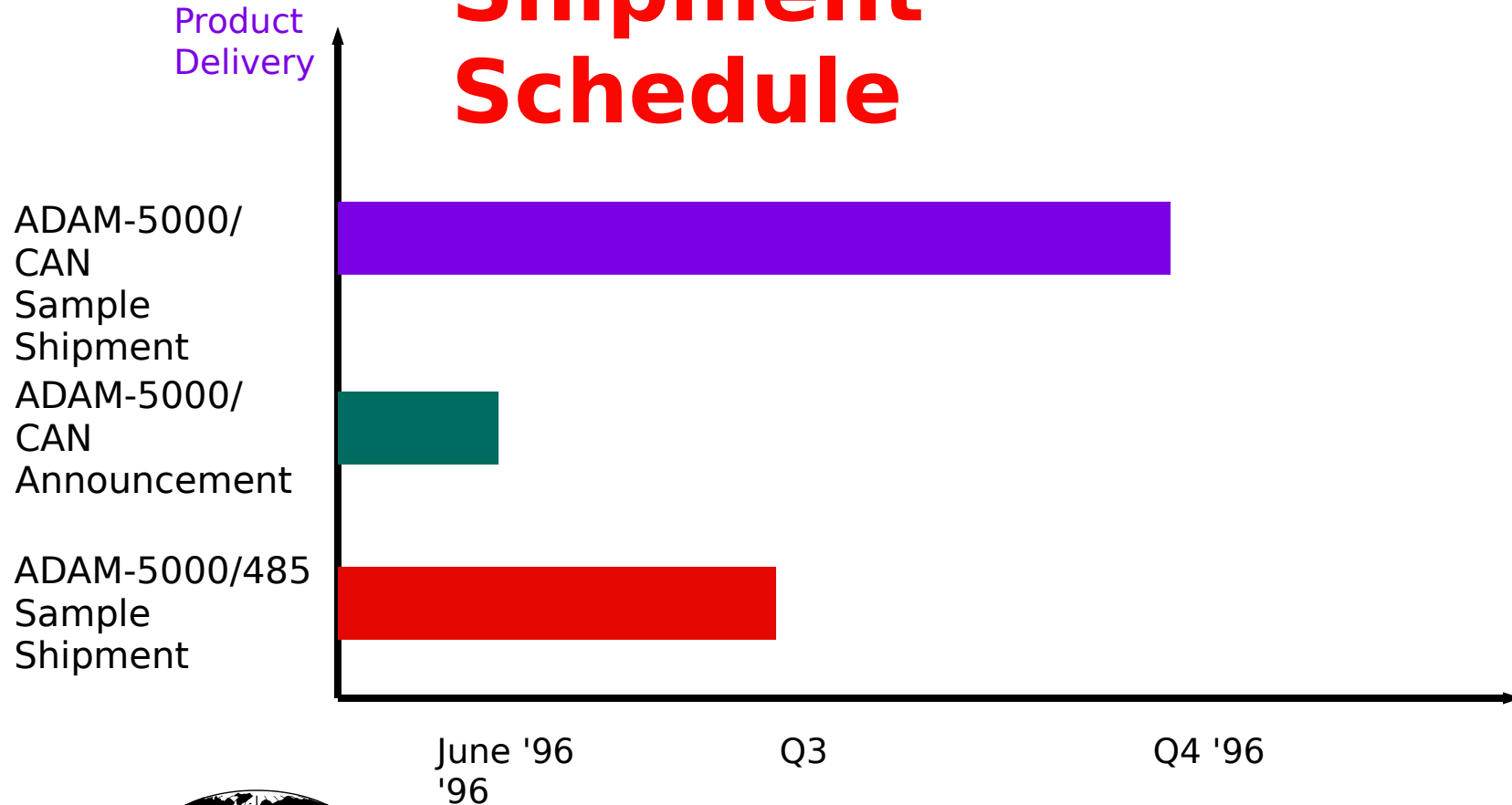

ADVANTECH.