

Welcome!



***Isolated Signal Conditioning Modules
ADAM-3000 Series***

**ADAM
3000
Series**

ADAM-3000 **Series** **Isolated Signal Conditioning Modules**

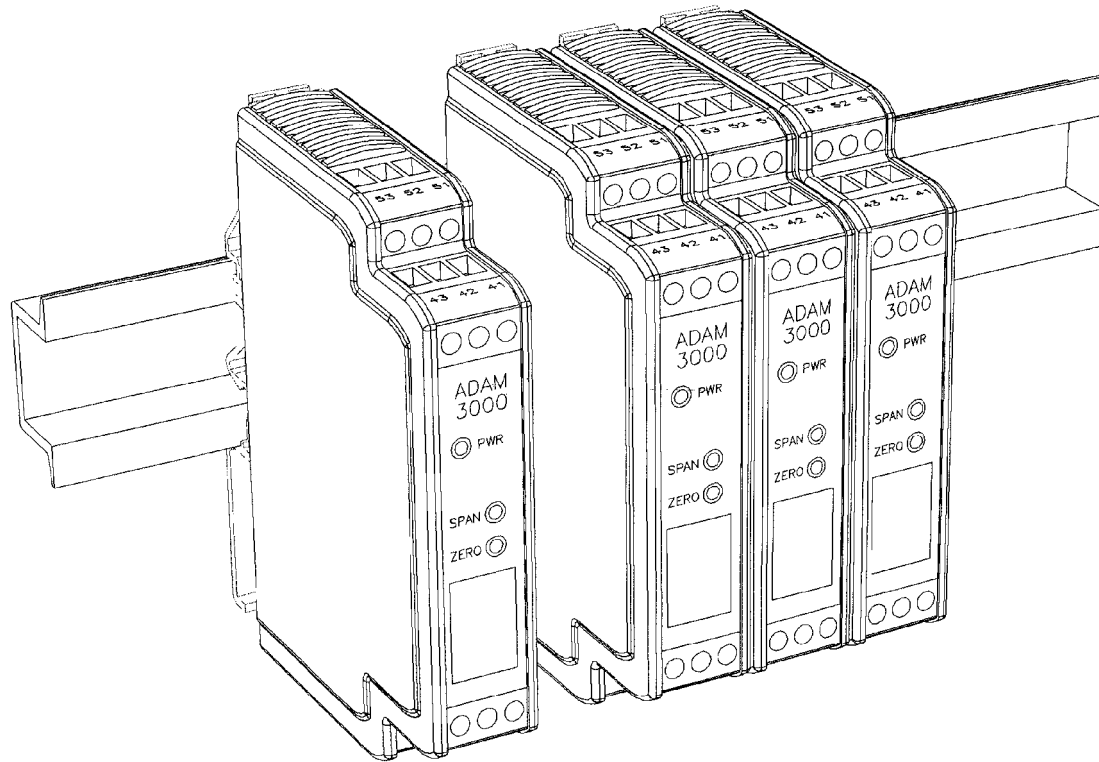

ADVANTECH.

Why ADAM-3000?

New optical isolator replaces
transformer

- + Flexible functionality reduces stock
- + Reliable design shorten lead time
- + Low power consumption saves you money
- + Lowest Price in the world

= **Price/Performance Leader**



Data Acquisition/Control Process Loop

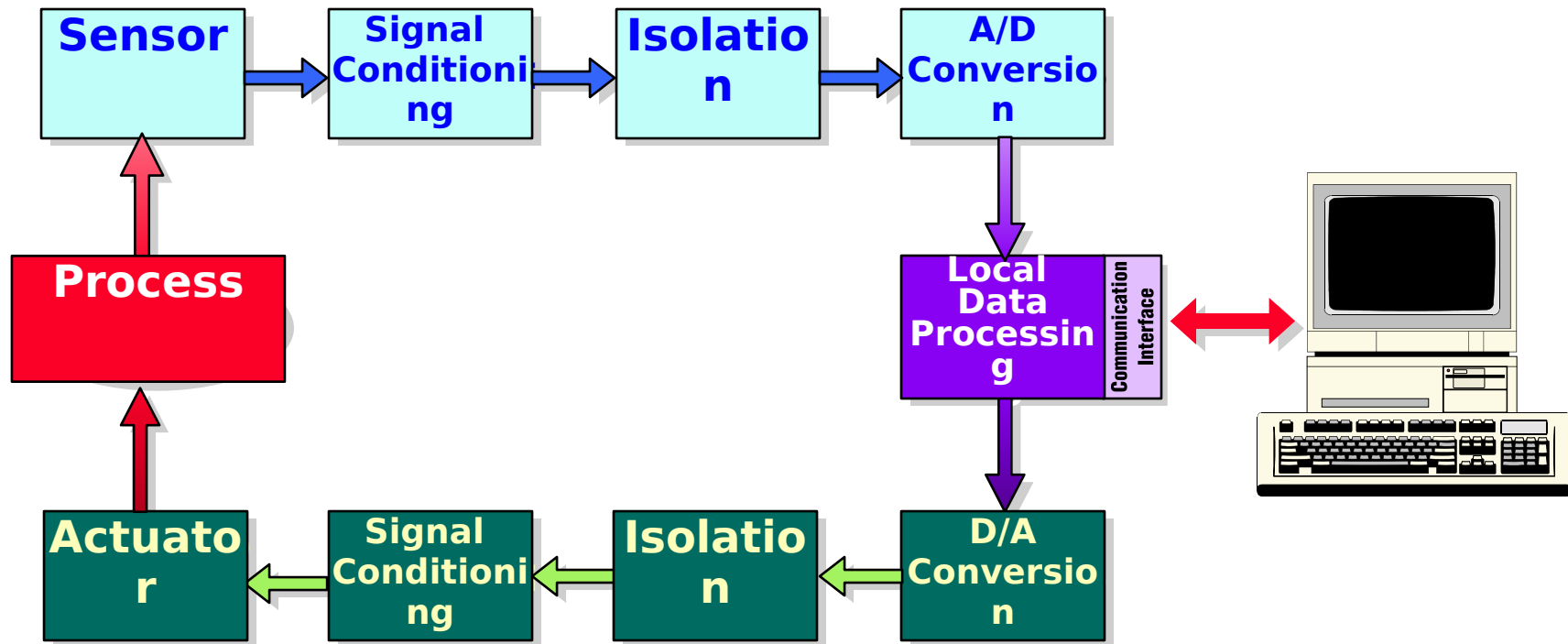

**ADAM
3000
Series**

ADAM-3000 Series

Isolated Signal Conditioning Modules

ADAM-3012

 Isolated DC-input Signal Conditioning Module

ADAM-3021

 Isolated DC-output Signal Conditioning Module

ADAM-3011

 J Type Thermocouple Input Signal Conditioning Module

 K Type Thermocouple Input Signal Conditioning Module

 T Type Thermocouple input Signal Conditioning

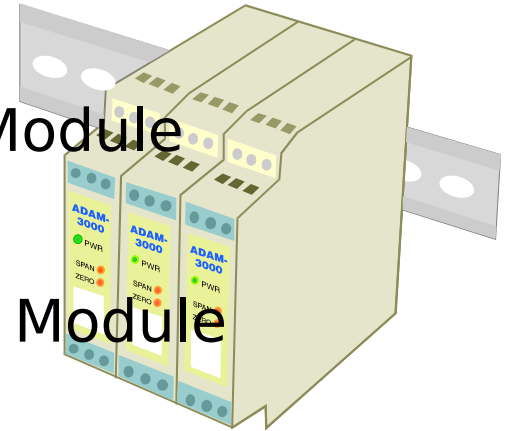

ADVANTECH.

Three-Way Signal Isolation

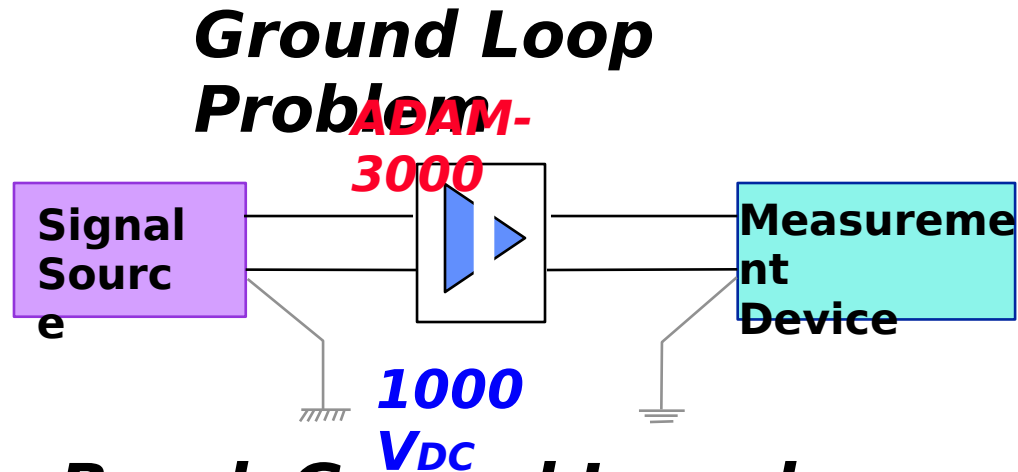
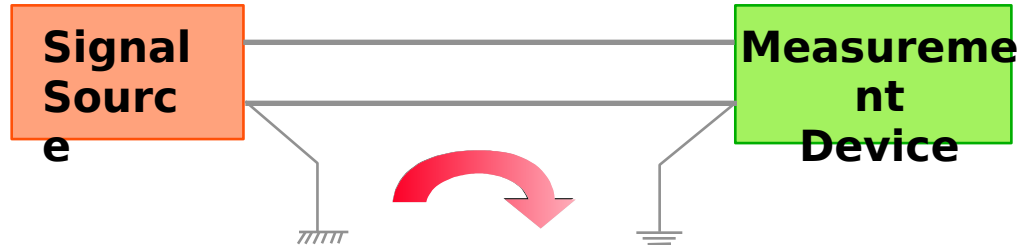

**Break Ground Loop by
Signal Isolation**



ADAM
3000
Series

Field Configurable I/O

Range

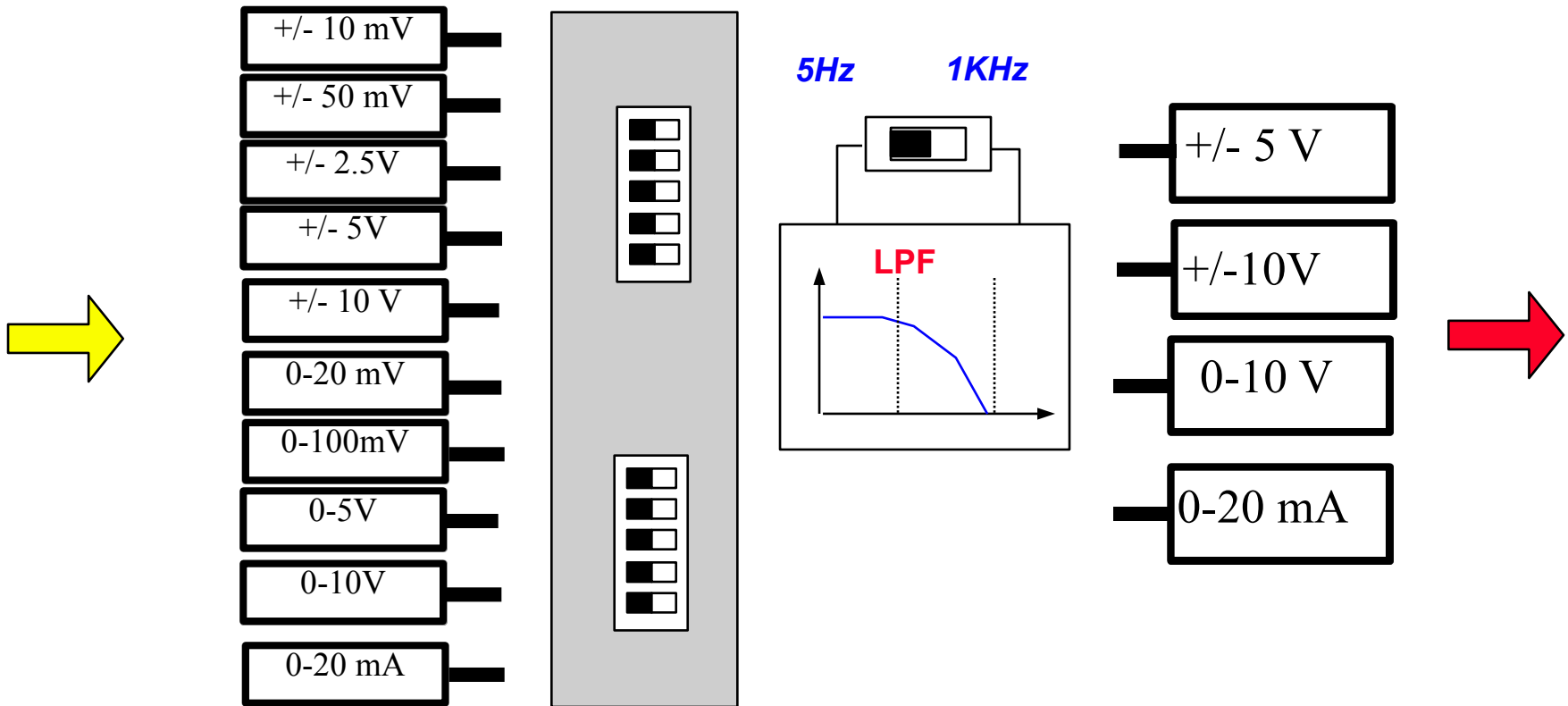

ADVANTECH.

**ADAM
3000
Series**

Easy Power Wiring

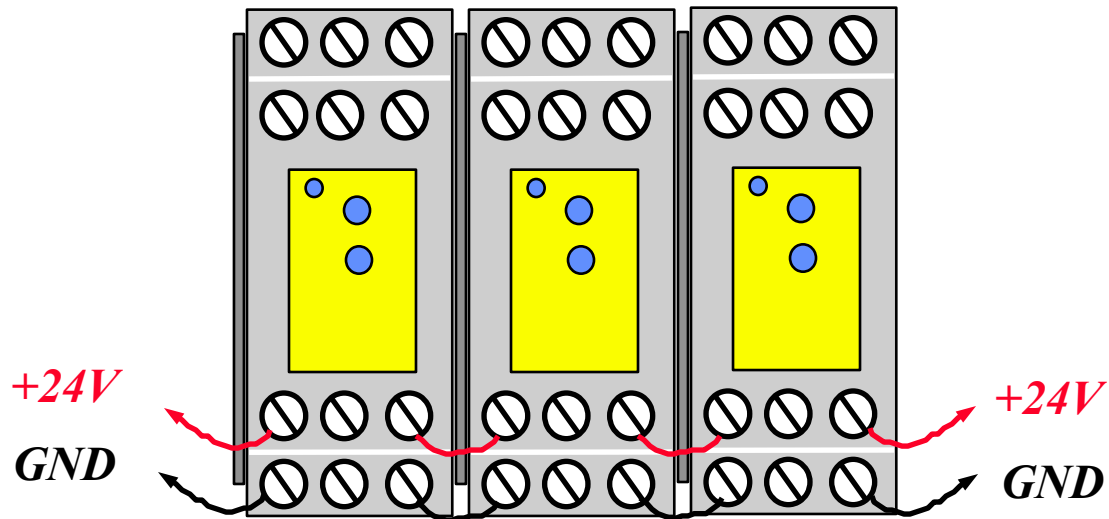

ADVANTECH.

Thermocouple Measurement

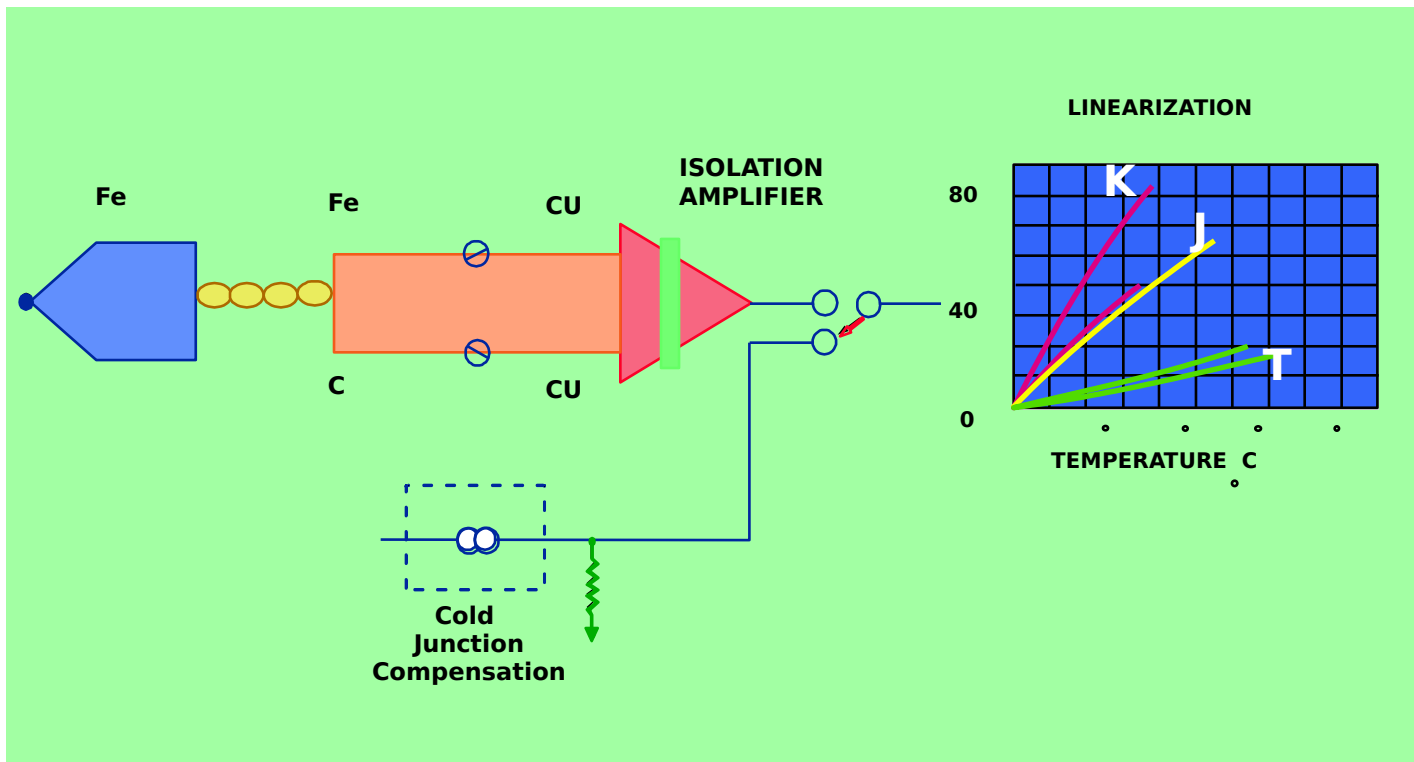

**ADAM
3000
Series**

Flexible DIN-Rail Mounting

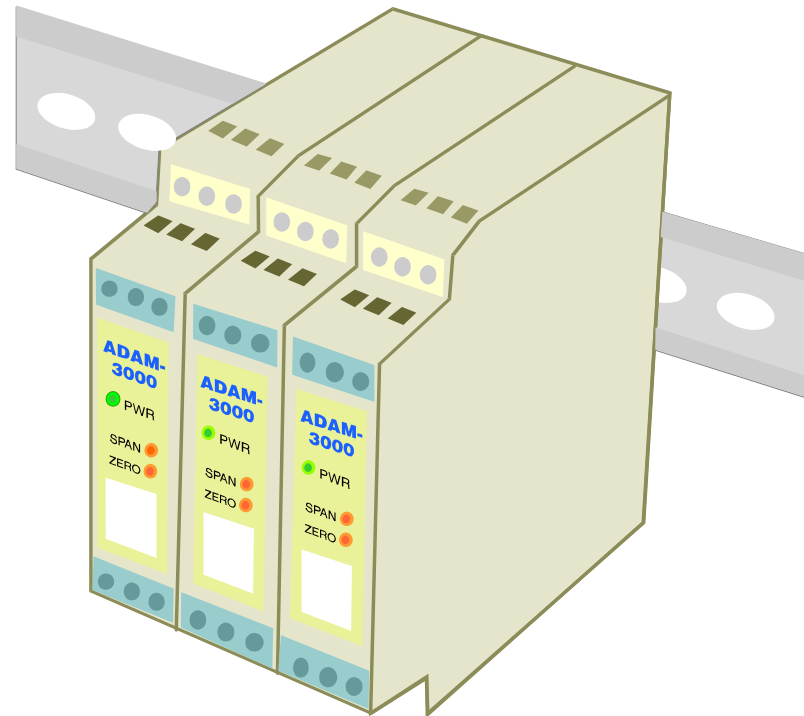

ADVANTECH.

Applications

 Signal Isolator for Factory Automations

 Signal Transmitter for Factory Automations

 Temperature Measurement for PLC & DCS

 Signal Amplifier for Measurement System

 Noise Filter for Measurement System

 Industrial ON/OFF Control

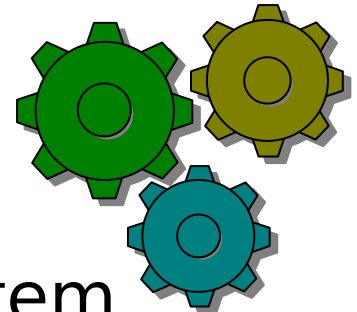

**ADAM
3000
Series**

Easily Connect to Industrial I/O Card

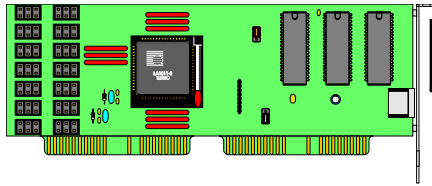

***Data Acquisition &
Control Card***

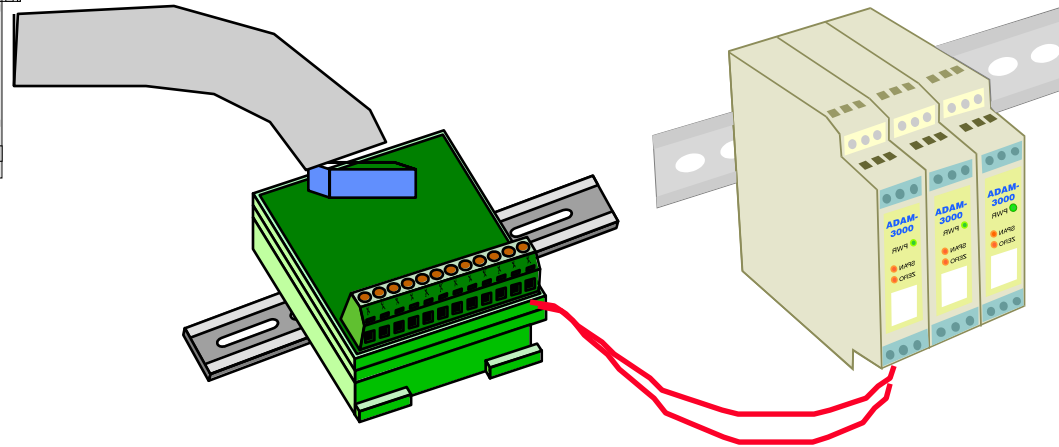

***DIN-Rail Wiring
Adaptor***



ADVANTECH.

**ADAM
3000
Series**

Directly Connect to PLC

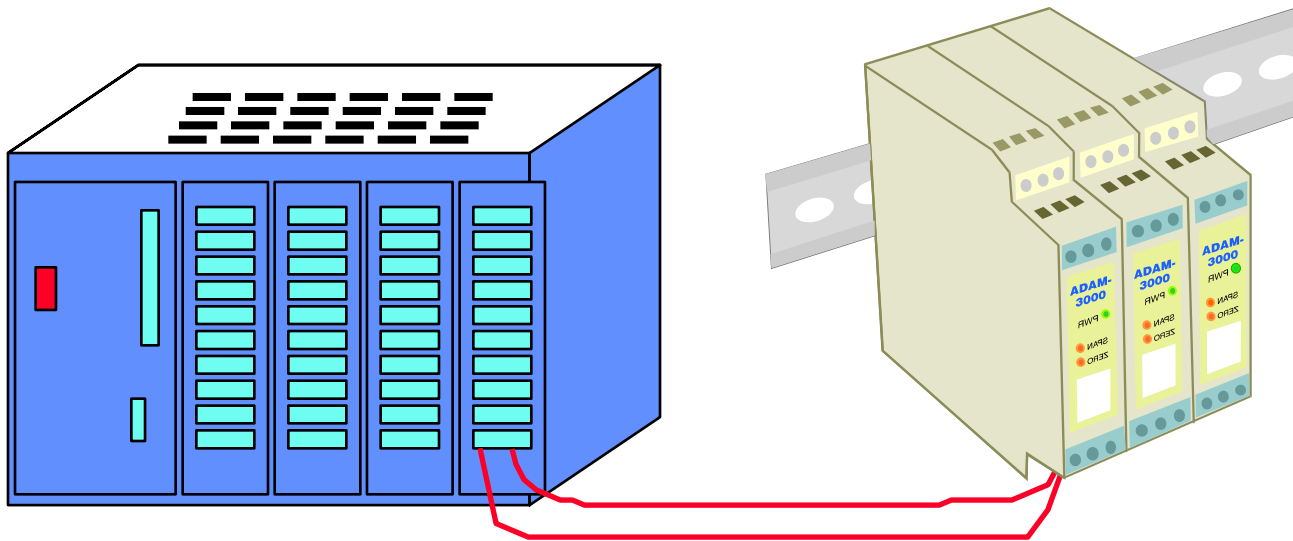

ADVANTECH.

**ADAM
3000
Series**

Analog Data Transmitter

**Process
Signal**

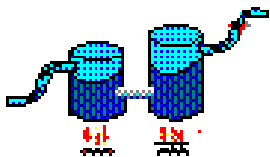

**Transmit
ter**

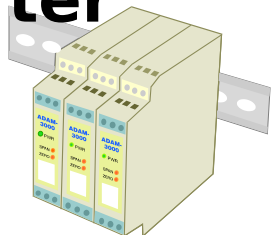

**0-20
mA**

**4-20
mA**



**EMI
Noise
Immuni
ty**

**Control
Room**

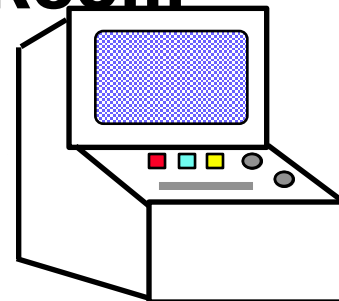

ADVANTECH.

**ADAM
3000
Series**







Marketing Survey

	Analog Device 3839	Analog Device 3831	ACTION G408	OMEGA PRN-PR	ADAM-3012
Stability	55ppm/ C	55ppm/ C	250ppm /C	N/A	17.7ppm /C
Power	0.85 W	1.4 W	1.5 W	2.4 W	0.8 W
Range	Fixed	Fixed	Configurable	Configurable	Configurable
Response	4Hz	3Hz	5Hz	3Hz	5Hz/ 1KHz
Mount	Backplane	Backplane	DIN Rail	DIN Rail	DIN Rail
Price	\$150	\$110	\$197	\$295	\$130



ADVANTECH.

Feature & Benefit

-  1000 V_{DC}, Three-Way Isolation
-  Field Configurable I/O Range
-  Easy Power Wiring
-  Linearized Thermocouple Measurement
-  Flexible DIN-Rail Mounting
-  Most Cost-Effective Signal Conditioner

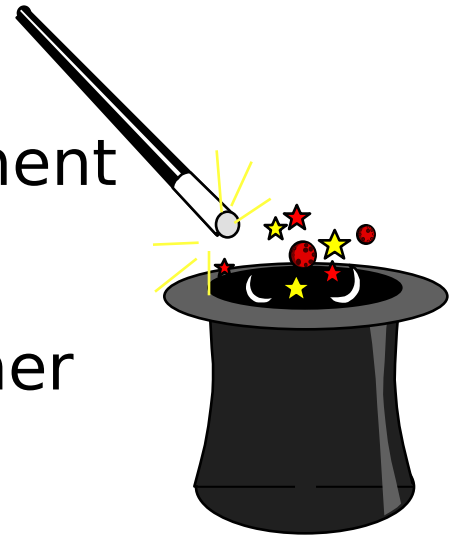

**ADAM
3000
Series**

Block Diagram of ADAM-3012

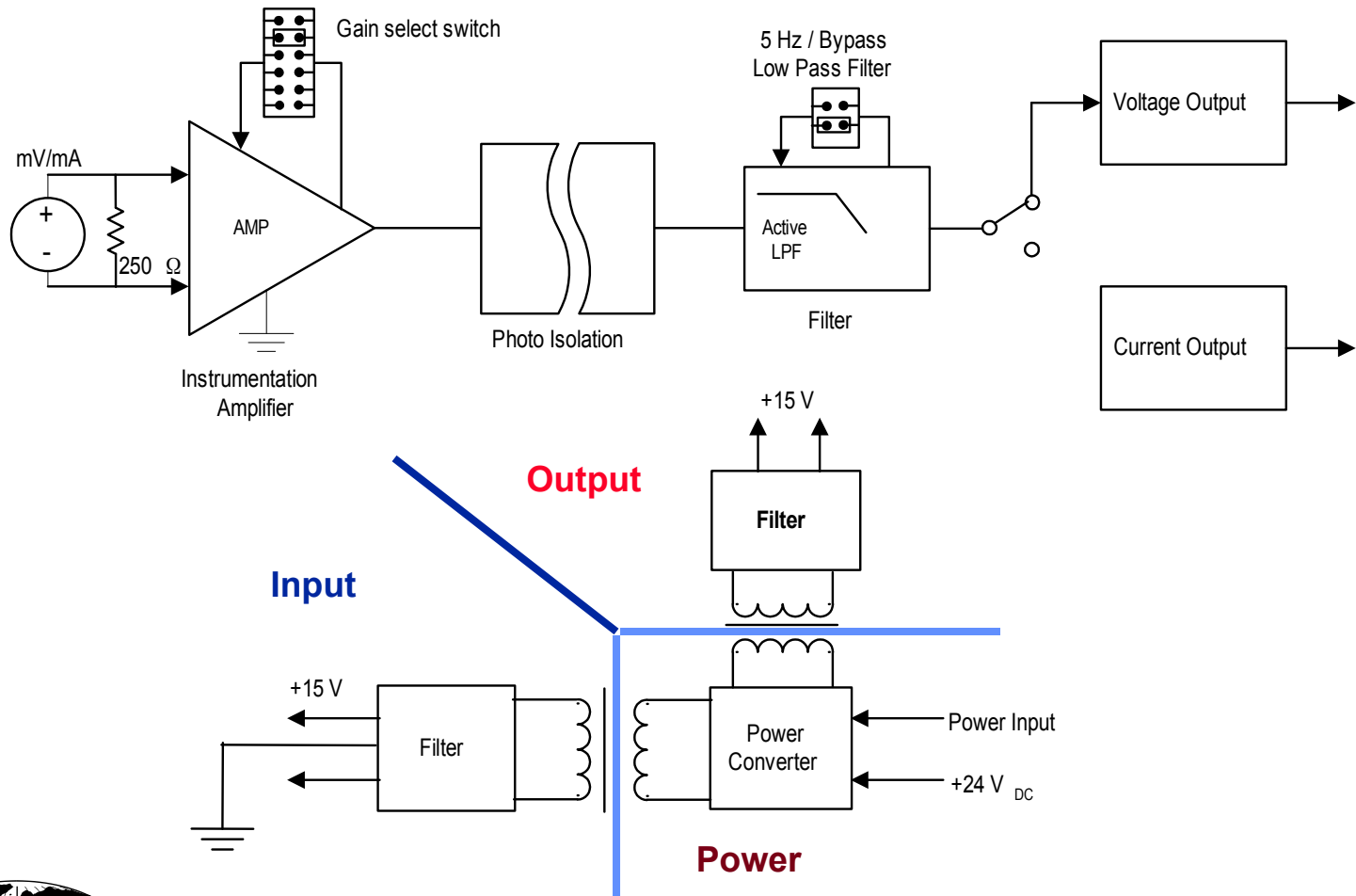

ADVANTECH.

Better EMI immunity

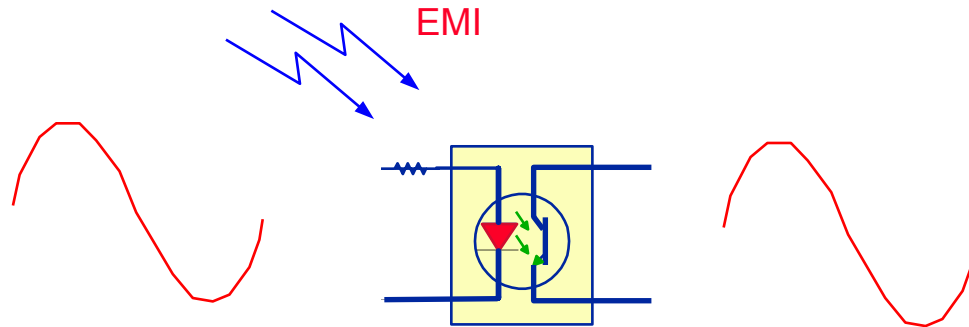

Optical Isolation provides better EMI immunity

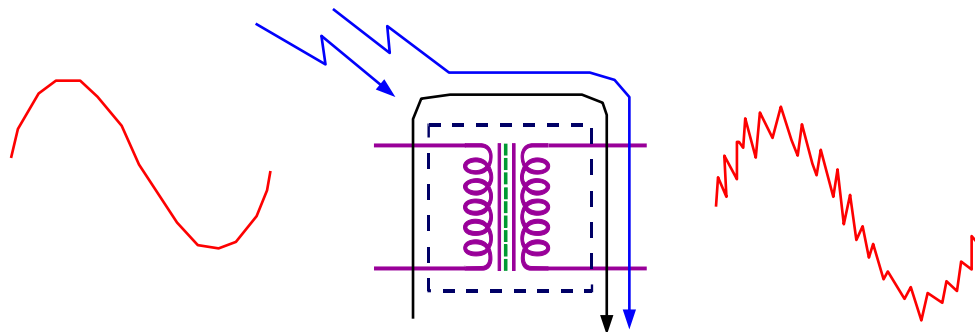

Transformer Isolator sensitive to EMI



DIN Rail Digital I/O modules

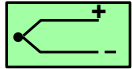

Measure

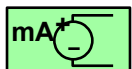
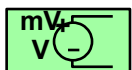
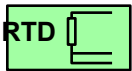

**Power relay outputs module
(relay ;Ñ 4)**



SSR carrier module (socket ;Ñ 4)



**Wiring terminal adapter (DB37/
20 pins)**



**24 VDC 48W power supply (90-
240VAC in)**



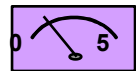





Control



1999



Power relay output module

-  Relay Type : SPDT (Form C)
-  Four on board power relays
-  Contact rating:
 -  AC:250V@5A
 -  DC: 30V@5A
-  Varistor to surge voltage of inductive load
-  LED channel status indicator
-  Control Logic: 24 VDC

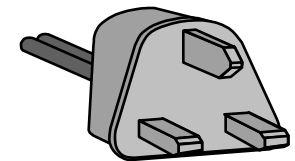

SSR Carrier module

- NVL Four-Channel Carrier Backplane**
- NVL Ready for any combination of AC/DC I/O modules (IDC24, OAC24A etc)**
- NVL LED Channel status indicator**
- NVL On-board fuse protection**
- NVL Control logic: 24VDC**



**ADAM
3000
Series**

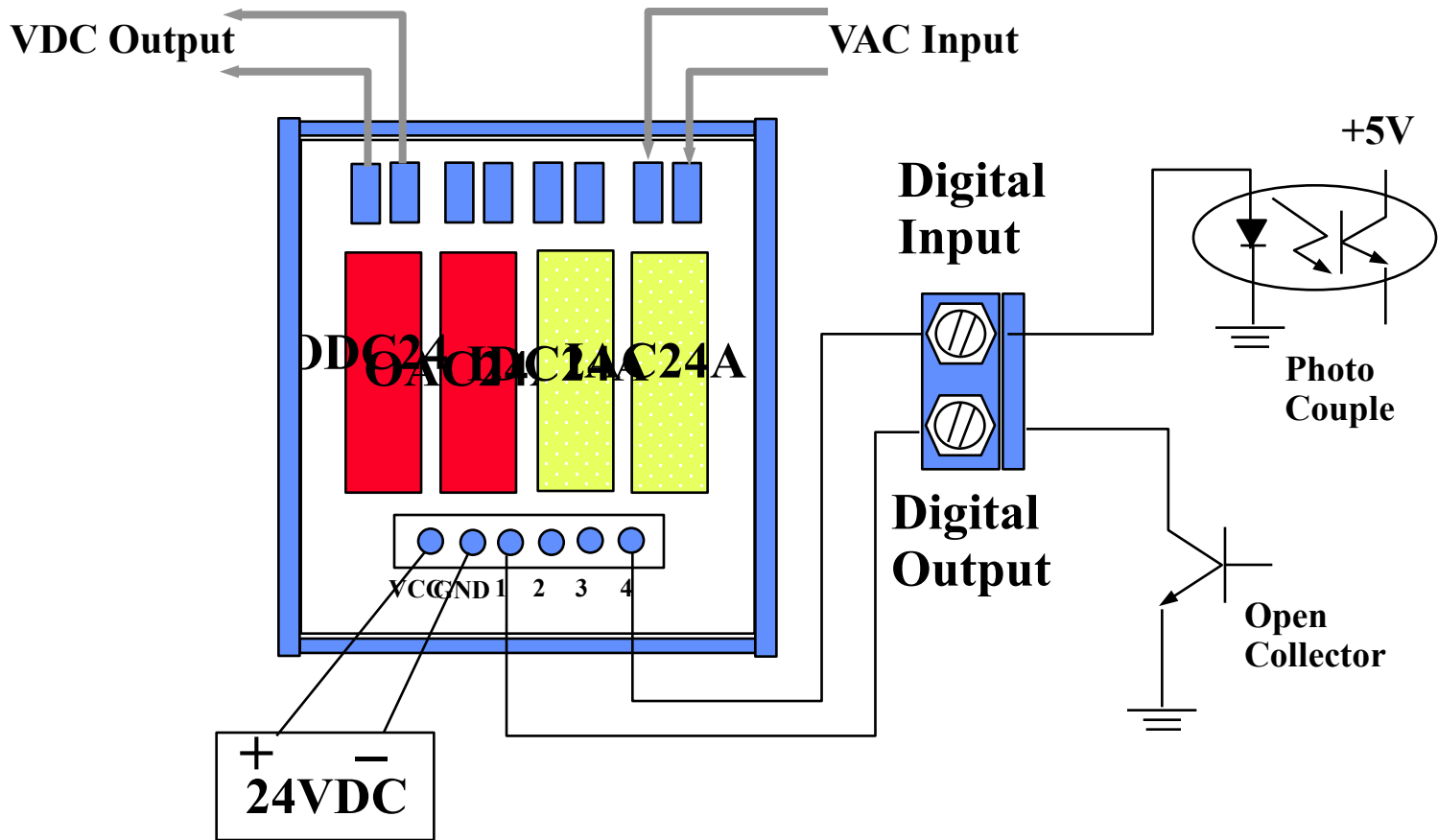

Easy wiring to SSR module



ADVANTECH.

**ADAM
3000
Series**

ADAM-3000 series **Signal Conditioning Modules**

-  Isolated Analog I/O interface modules
-  Digital I/O interface modules
-  Wiring Adapter and Power supply

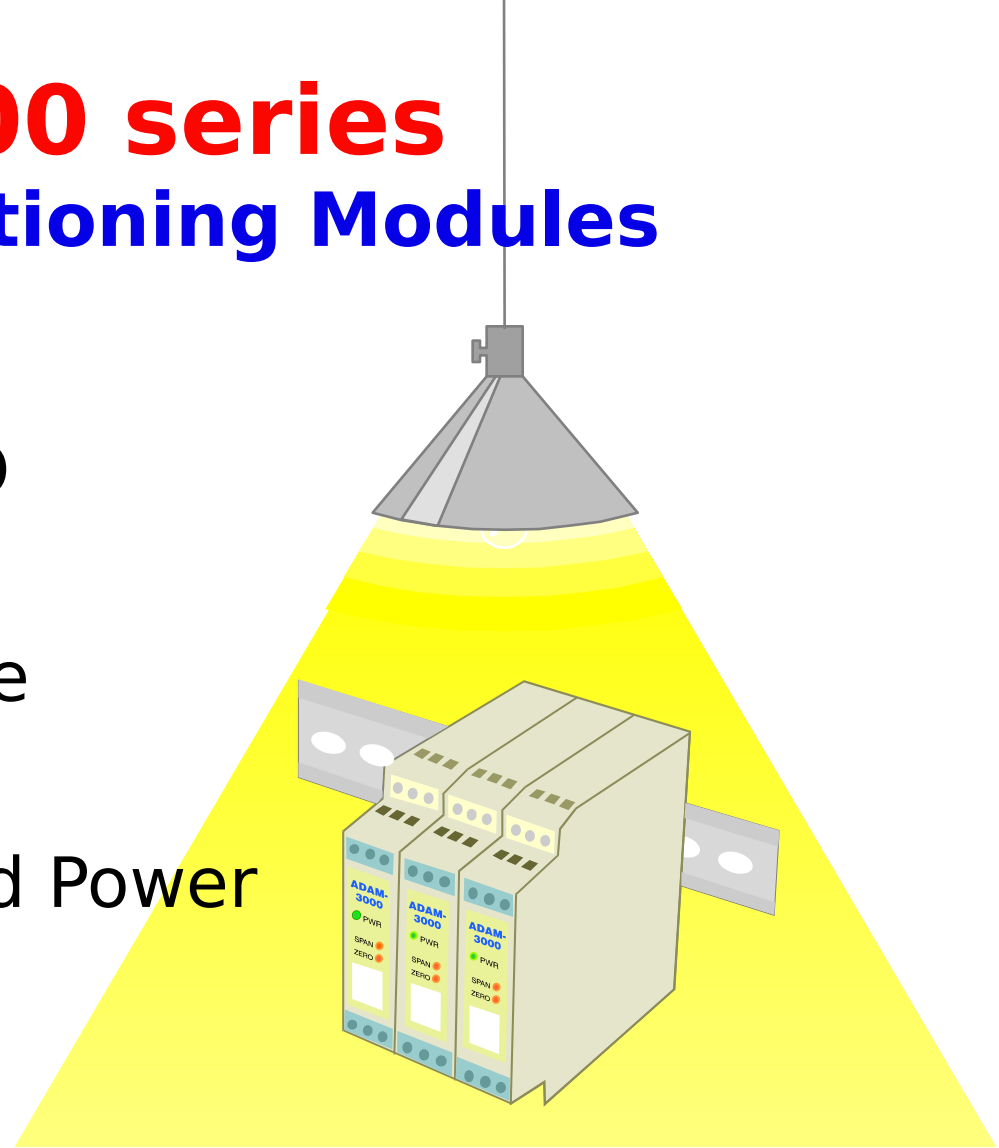

ADVANTECH.

ADAM-3012

Isolated DC-input Signal Conditioning Module

 1000 VDC Three-way Isolation

 Switch configurable input range

 Voltage: +/- 10 mV, +/-50 mV, +/-0.5V, +/-2.5V, +/-5V
0-20 mV, 0-100mV, 0-1V, 0-5V, 0-10V

 Current: +/- 20 mA, 0-20 mA

 Switch configurable output range

 Voltage: +/- 5V, 0-10V

 Current: 0-20 mA

 Switch Configurable input
bandwidth: 5Hz/1KHz



ADAM-3021

Isolated DC-output Signal Conditioning Modules

 1000 V_{DC} Three-way isolation

 Voltage output mode

input: +/-5V, +/-10V

output: +/-10V

 Current output mode

input: 0-5V, 0-10V

output: 0-20 mA





1-5V, 2-10V

4-20 mA



ADAM-3011

Thermocouple Input module

-  1000 VDC three-way isolation
-  J, K, T type thermocouple input
-  Cold Junction Compensation
-  Thermocouple Linearization
-  Output range: 0-10V



ADAM-3854





Power relay output module

- NUL Relay Type : SPDT (Form C)**
- NUL Four on board power relays**
- NUL Contact rating:**
 - NUL AC:250V@5A**
 - NUL DC: 30V@5A**
- NUL Varistor to surge voltage of inductive load**
- NUL LED channel status indicator**
- NUL Control Logic: 24 VDC**



ADAM-3864

SSR Carrier module

-  **Four-Channel Carrier Backplane**
-  **Ready for any combination of AC/DC I/O modules (IDC24, OAC24A etc)**
-  **LED Channel status indicator**
-  **On-board fuse protection**
-  **Control logic: 24 VDC**



ADAM-3920/3937

Wiring Terminal Adapter

ADAM-3920

 DIN Rail Wiring Terminal for 20 pin flat cable

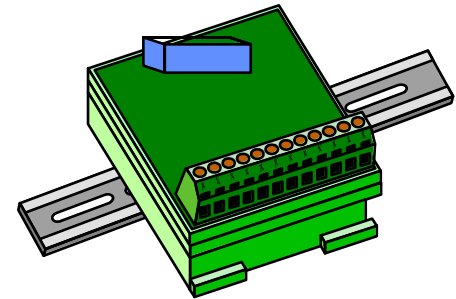

ADAM-3937

 DIN Rail Wiring Terminal for DB37 cable



PWR-245

DIN Rail 24VDC (48W) Switching Power Supply

-  Input Voltage: 90-264 VAC
-  Output Voltage: 24VDC +/- 10%
-  Output Current: 2.1A

