

Intel® StrongARM* SA-1110 Processor

High-Performance, Low-Power Processor for Portable Wireless Multi-Media Devices

Product Highlights

- Innovative Application Specific Standard Product (ASSP) delivers leadership performance, integration and low power for palm-size devices, PC companions, smart phones and other emerging wireless multi-media devices
- High-speed 100 MHz memory bus and a flexible memory controller that adds support for SDRAM, SMROM, and variable-latency I/O devices – provides design flexibility, scalability and high memory bandwidth
- Rich development environment enables leading edge products while reducing time-to-market

SA-1110 provides the performance, low power, integration and cost benefits of the Intel SA-1100 processor plus a high speed memory bus, flexible memory controller and the ability to handle variable-latency I/O devices such as high performance graphic devices. Manufacturers who utilize the cost-effective SA-1110 ASSP benefit from this high-value feature set, which is complemented by a robust development environment that speeds time-to-market.

'System on a Chip' Integration Delivers Cost-Effective Solutions

The Intel SA-1110 processor consists of:

- **Processing Core** – the processor is the Intel SA-1 core with a 16 Kbyte instruction and 8 Kbyte data cache, memory-management units, read and write buffers and a 512 byte mini-data cache that can be utilized to enhance caching performance when dealing with frequently used data structures
- **Memory and PCMCIA Control Module** – flexible memory controller supporting SDRAM, Synchronous Mask ROM, ROM, Flash, DRAM, SRAM, SRAM-like variable-latency I/O and PCMCIA control signals.
- **System Control Module** – 28 general-purpose interruptible I/O ports, real-time clock, watchdog, interval timers, power management controller, interrupt controller, reset controller, and two on-chip oscillators.
- **Peripheral Control Module** – six channel DMA controller, LCD controller, SDLC controller, 16550 compatible UART, IrDA serial port, synchronous serial port, USB end point interface, and codec interface The Intel SA-1110 is offered in a small footprint 256-pin mBGA package.

Product Line Overview

As businesses and individuals rely increasingly on portable wireless devices to simplify their lives and boost their productivity, these devices have to perform more complex functions quickly and efficiently. To satisfy ever-increasing customer demands to communicate and access information 'anytime, anywhere', manufacturers need technologies that deliver high-performance, robust functionality and versatility while meeting the small-size and low-power restrictions of portable, battery-operated products. Intel designed the SA-1110 processor with all of these requirements in mind.

The Intel® SA-1110 is a highly integrated 32-bit Intel® StrongARM* processor that incorporates Intel design and process technology along with the power efficiency of the ARM* architecture. The SA-1110 is software compliant with the ARM V4 architecture while utilizing a high-performance micro-architecture that is optimized to take advantage of Intel process technology. The Intel

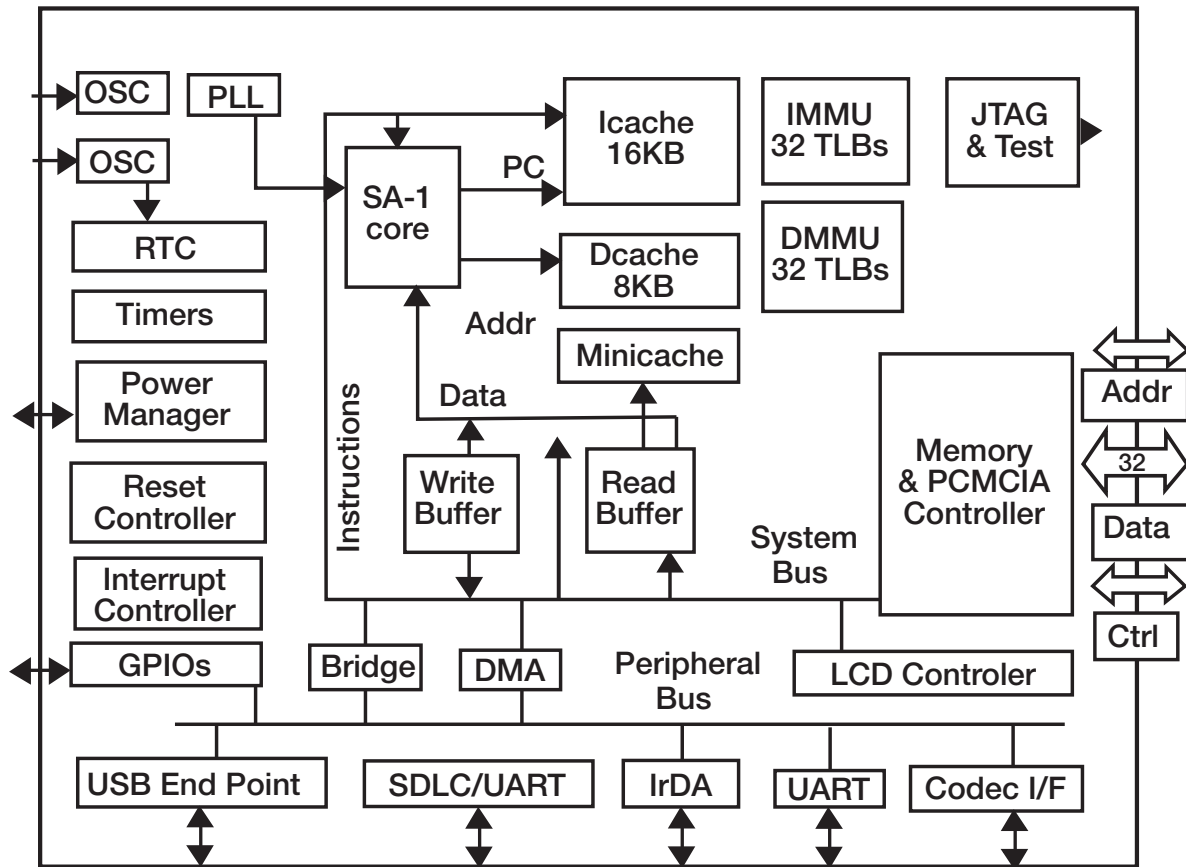

SA-1110 Block Diagram

Leadership Performance and Low Power

Today's system designers are faced with the challenge of providing greater product performance and functionality while maintaining power requirements. The Intel SA-1110 has the unique ability to provide both leadership performance and low power. The SA-1110 processor achieves its leadership MIPS/mW by taking advantage of a high-performance micro-architecture, advanced CMOS process technology, and large on-chip memory caches. Power utilization is optimized through a low-voltage process technology that enables the SA-1110 integrated power management unit to conserve battery usage whenever tasks are not activating the system.

The high bandwidth of the Intel SA-1110 allows portable devices to provide faster response by utilizing operating systems and performance intensive applications like MP3 audio decode, MPEG4 video decode, speech and handwriting recognition, soft modem, and Java interpretation more effectively. This ability enables portable devices based upon the SA-1110 to provide greater functionality and to deliver a richer internet experience.

Advanced Controller Increases Memory Speed, Flexibility and I/O Versatility

The Intel SA-1110 advanced memory controller operates up to 100 MHz and supports four banks of either synchronous, fast-page-mode, or extended-data-out DRAM, providing manufacturers with more memory design alternatives to meet target cost and performance requirements. Additionally, the SA-1110 memory controller supports three banks of static memory-ROM, Flash, SRAM, and/or synchronous mask ROM (SMROM). The memory controller can access all supported memory types and I/O devices on either a 16- or 32-bit bus (with the exception of SMROM which is 32-bit

only). This flexibility enables cost-effective, low component count designs. The Intel SA-1110's support for variable-latency I/O devices makes it well-suited for designs that require a range of complementary devices like the Intel® StrongARM® SA-1111 companion chip and/or external graphics controllers. This versatility enables system performance to scale across the full range of portable applied computing—from palm-size devices that demand a highly integrated solution to high-end PC companions that require additional I/O and greater graphics performance.

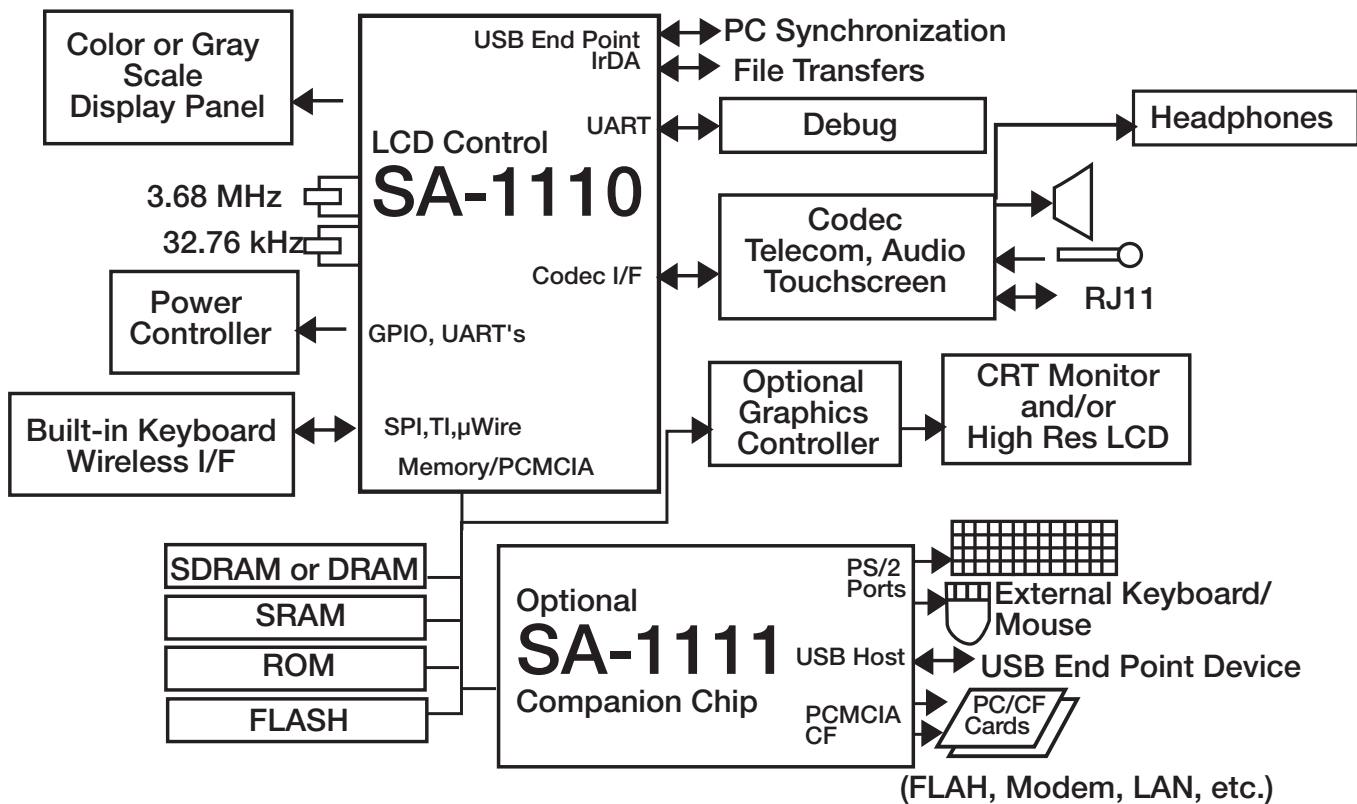

SA-1110/SA-1111 System Example

Rich Development Environment Speeds Time-To-Market

Complementing the Intel SA-1110 high performance/low power attributes is a robust software and hardware development environment. Developers have access to a large library of ARM-compliant applications and tools plus an abundant set of operating systems and tool chains, including real-time and interactive development systems. Developers

can use these resources to build libraries of new feature-rich, industry leading applications for Intel StrongARM-based products and reduce overall time-to-market. Both the Intel SA-1110 and SA-1111 are available in volume production today.

SA-1110 MICROPROCESSOR

SPEED (MHz)	PERFORMANCE	CORE POWER SUPPLY (VDC), NOMINAL	I/O POWER SUPPLY (VDC), NOMINAL	TYPICAL POWER DISSIPATION (mW)	AMBIENT OPERATING TEMPERATURE	STORAGE TEMPERATURE	PROCESS TECHNOLOGY	TRANSISTOR COUNT	PACKAGING	ORDER NUMBER
133	150 Dhrystone 2.1 MIPS	V _{ss} =0.0 VDC V _{dd} =1.55 VDC	V _{ssx} =0.0 VDC V _{ddx} =3.3 VDC	Normal Mode=<240 mW Idle Mode=<75 mW Sleep Mode=<50 uA	0°C (32°F) min 70°C (158°F) max	-20°C to +125°C (-4°F to +257°F)	0.35 µm, 3-layer metal	2.5 Million	256 mBGA	SA1110AC
206	235 Dhrystone 2.1 MIPS	V _{ss} =0.0 VDC V _{dd} =1.75 VDC	V _{ssx} =0.0 VDC V _{ddx} =3.3 VDC	Normal Mode=<400 mW Idle Mode=<100 mW Sleep Mode=<50 uA	0°C (32°F) min 70°C (158°F) max	-20°C to +125°C (-4°F to +257°F)	0.35 µm, 3-layer metal	2.5 Million	256 mBGA	SA1110BC

* Legal Information and Privacy Policy © 2001 Intel Corporation

Ordering Information

For SA-1110 Microprocessor Characteristics and Ordering Information:
See SA-1110 Linecard

To Order Now:
Contact an Intel authorized distributor

Intel Access

Developer's Site	developer.intel.com
Other Intel Support:	developer.intel.com/design/litcentr
Intel Literature Center	(800) 548-4725 7 a.m. to 7 p.m. CST (U.S. and Canada) International locations please contact your local sales office.
General Information Hotline	(800) 628-8686 or (916) 356-3104 5 a.m. to 5 p.m. PST

Information in this document is provided in connection with Intel products. No license, express or implied, by estoppel or otherwise, to any intellectual property rights is granted by this document. Except as provided in Intel's Terms and Conditions of Sale for such products, Intel assumes no liability whatsoever, and Intel disclaims any express or implied warranty, relating to sale and/or use of Intel products including liability or warranties relating to fitness for a particular purpose, merchantability, or infringement of any patent, copyright or other intellectual property right. Intel products are not intended for use in medical, life saving, or life sustaining applications. Intel may make changes to specifications and product descriptions at any time, without notice.

Designers must not rely on the absence or characteristics of any features or instructions marked "reserved" or "unrefined." Intel reserves these for future definition and shall have no responsibility whatsoever for conflicts or incompatibilities arising from future changes to them.

Intel is a registered trademark of Intel Corporation.

* Third-party marks and names are the property of their respective owners.



For more information, visit the Intel Web site at: developer.intel.com

UNITED STATES AND CANADA
Intel Corporation
Robert Noyce Bldg.
2200 Mission College Blvd.
P.O. Box 58119
Santa Clara, CA 95052-8119
USA

EUROPE
Intel Corporation (UK) Ltd.
Pipers Way
Swindon
Wiltshire SN3 1RJ
UK

ASIA-PACIFIC
Intel Semiconductor Ltd.
32/F Two Pacific Place
88 Queensway, Central
Hong Kong, SAR

JAPAN
Intel Kabushiki Kaisha
P.O. Box 115 Tsukuba-gakuen
5-6 Tokodai, Tsukuba-shi
Ibaraki-ken 305
Japan

SOUTH AMERICA
Intel Semicondutores do Brazil
Rue Florida, 1703-2 and CJ22
CEP 04565-001 Sao Paulo-SP
Brazil