

How Do I?

Select the button next to the topic you want to learn more about:



[Replace Ink Cartridges](#)



[Load Paper](#)



[Change Print Settings](#)



[Print on a Variety of Paper Types and Sizes](#)



[Replace Printheads](#)



[Contact HP](#)



HEWLETT
PACKARD

Build Tag Spacer for Win31

Select a Paper Tray

STEP 1 OF 3



1 Click here  to open the Control Panel, then double-click **Printers**.

-or-

In the Main program group, double-click **Control Panel**, and then double-click **Printers**.



Build Tag Spacer for Win31

Select a Paper Tray

STEP 2 OF 3



2 Select your printer in the **Installed Printers** list, and then click **Setup**.



Build Tag Spacer

Select a Paper Tray

STEP 3 OF 3

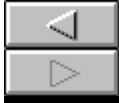

- 3 Click the **Setup** tab. From the **Paper Source** list, choose the tray from which you want the printer to pull paper. This will be the default setting for all print jobs.



Load Paper

The standard HP 2000C Series printer has one paper tray in which you can load paper and a Single-Envelope Slot for loading one envelope or card at a time. If you have the [optional HP 2000C Accessory Paper Tray](#), installed, you can also load paper in that tray.

Click one of the following topics to learn how to load paper:

- [IN Tray \(Standard Bin\)](#)
- [Single-Envelope Slot](#)
- [Optional Accessory Paper Tray](#)



Load Paper in the IN Tray (Standard Bin)

STEP 1 OF 3



- 1 Slide the paper length and width adjusters out to their fully extended positions.

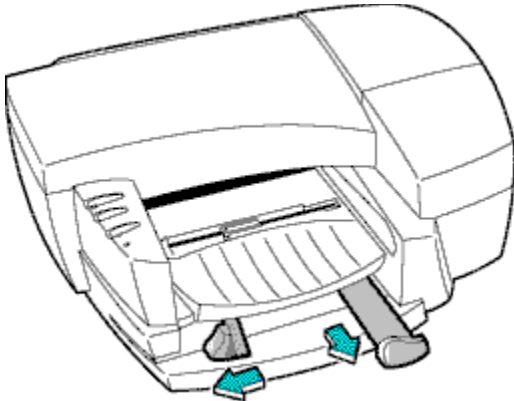

Load Paper in the IN Tray (Standard Bin)

STEP 2 OF 3



- 2 With the print side down, insert a stack of paper along the right edge of the IN Tray. The stack of paper should not be higher than the level indicator mark on the right side of the IN Tray.

Note: Too much paper can prevent the printer from picking up paper from the stack.

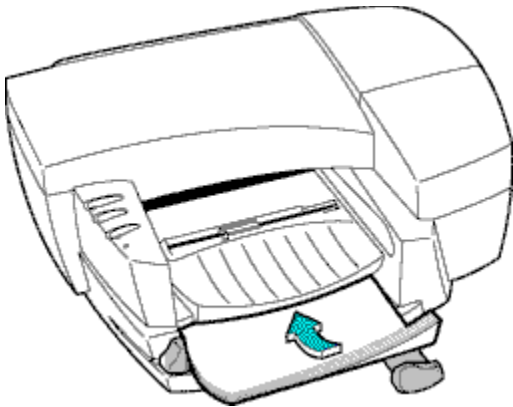

Load Paper in the IN Tray (Standard Bin)

STEP 3 OF 3

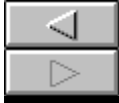

- 3 Slide the length and width adjusters to fit snugly against the edges of the stack. This keeps the paper straight as it feeds through the printer.

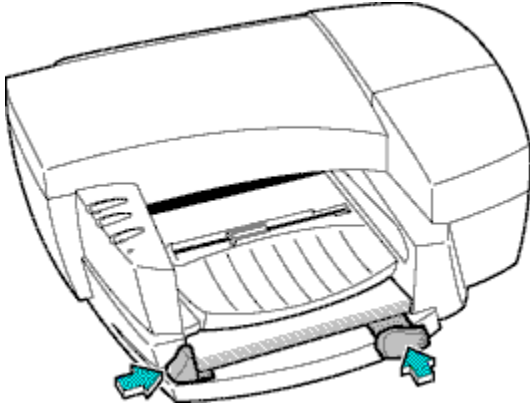

Optional Accessory Paper Tray

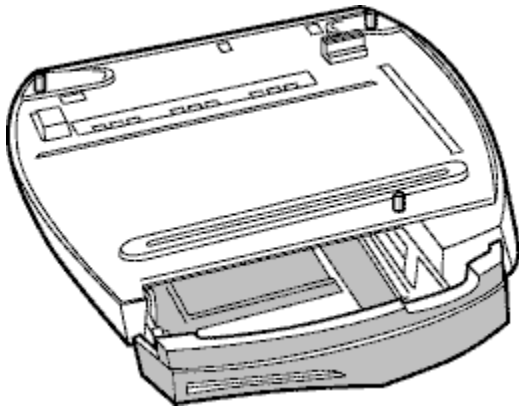

The optional HP 200C Accessory Paper Tray is a convenient and affordable way to expand the paper handling capacity of your printer. Use the accessory paper tray as a source of paper in addition to the IN Tray. Or, keep the paper you use most often in the accessory paper tray and only use the IN Tray to feed special media, such as letterhead or HP Deluxe Photo Paper.

Load Paper in the Single-Envelope Slot

STEP 1 OF 2

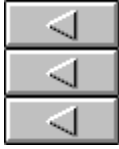

- 1 Slide the envelope evenly into the single-envelope slot, with the flap up and to the right, until it stops.

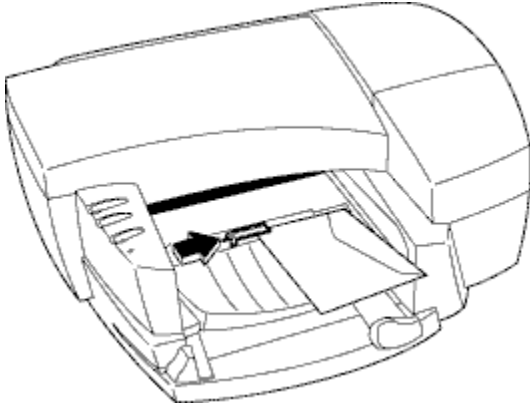

Load Paper in the Single-Envelope Slot

STEP 2 OF 2

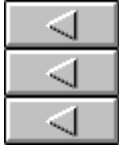

- 2 In the HP print settings dialog box, click the **Setup** tab. In the **Paper Size** box, select the size of envelope you are using, and then click **OK**. Print your envelope.

Click here  for information about changing print settings.



Load Paper in the optional Accessory Paper Tray

STEP 1 OF 5

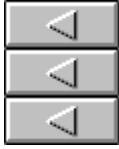

1 Open the optional Accessory Paper Tray.

Note: Your printer may not have this accessory. Click here  for more information.

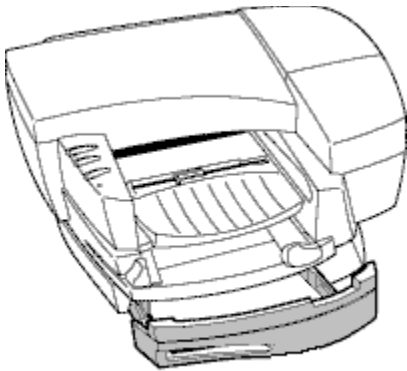

Load Paper in the optional Accessory Paper Tray

STEP 2 OF 5

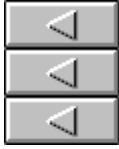

- 2 Slide the paper length and width adjusters inside the drawer out to their fully extended positions.

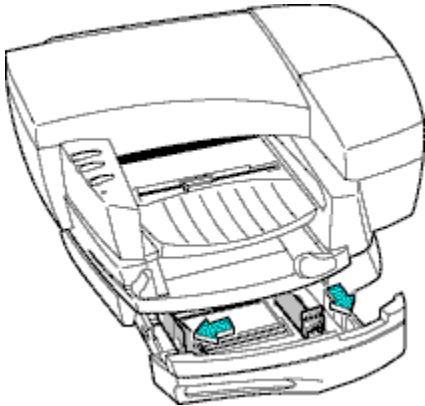

Load Paper in the optional Accessory Paper Tray

STEP 3 OF 5

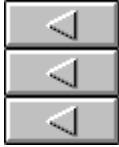

- 3 With the print side down, insert a stack of paper into the optional Accessory Paper Tray. The stack can be up to 250 sheets thick.

Note: Too much paper can prevent the printer from picking up paper from the stack.

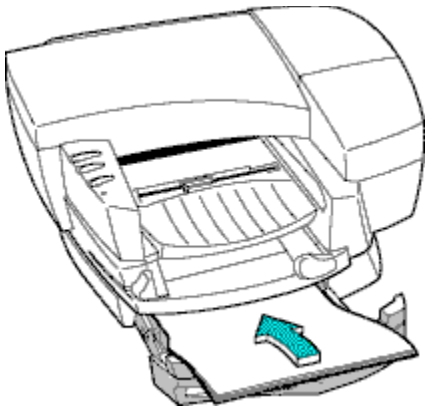

Load Paper in the optional Accessory Paper Tray

STEP 4 OF 5

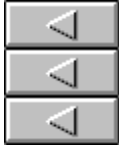

- 4 Slide the width and length adjusters to fit snugly against the edges of the stack. This keeps the paper straight as it feeds through the printer.

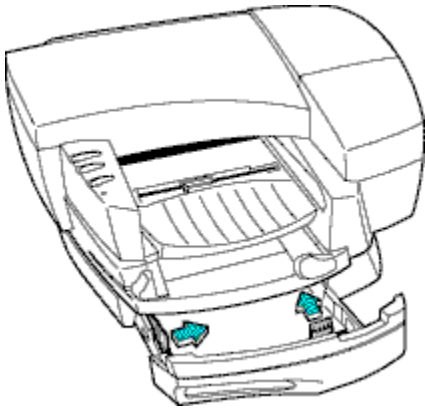

Load Paper in the optional Accessory Paper Tray

STEP 5 OF 5

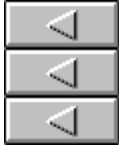

5 Close the optional Accessory Paper Tray.

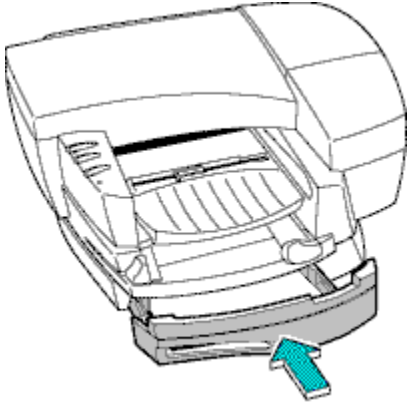

Use the Manual Feed Option

STEP 1 OF 6

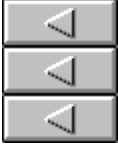

1 In the [HP print settings dialog box](#), click the **Setup** tab. Select **Manual Feed** from the **Paper Source** list.

Click here  for information about changing print settings.



Use the Manual Feed Option

STEP 2 OF 6

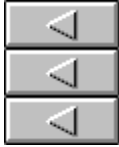

2 Print your document. The Resume (▶) light begins flashing.



Use the Manual Feed Option

STEP 3 OF 6

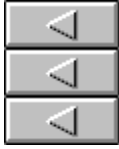

- 3 Slide the paper length and width adjusters out to their fully extended positions.

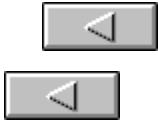

Use the Manual Feed Option

STEP 4 OF 6

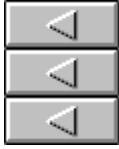

- 4 With the print side down, insert a stack of paper along the right edge of the IN Tray. The stack of paper should not be higher than the level indicator mark on the right side of the IN Tray.

Note: Too much paper can prevent the printer from picking up paper from the stack.

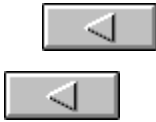

Use the Manual Feed Option

STEP 5 OF 6

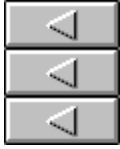

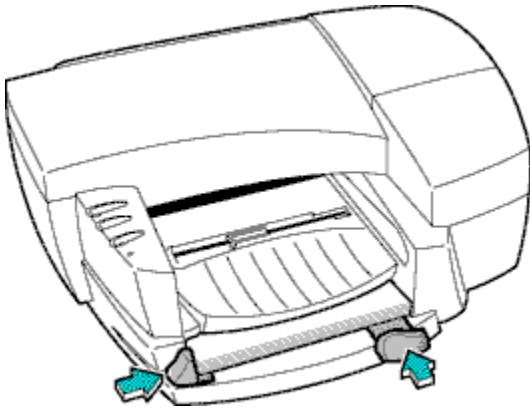

- 5 Slide the length and width adjusters to fit snugly against the edges of the stack. This keeps the paper straight as it feeds through the printer.

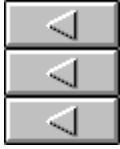

Use the Manual Feed Option

STEP 6 OF 6



6 Press the Resume  button on the printer to begin printing the document.

Note: When the **Manual Feed** option is selected, the Resume button must be pressed before printing each page in the document. After the document is printed, make sure to select a paper source other than **Manual Feed** in the HP print settings dialog box. The **Manual Feed** option will be active until you select another paper source.

Click here  for information about changing print settings.



The HP 2000C Toolbox



The HP 2000C Toolbox provides access to the information you need to use your printer, including procedures for basic printer tasks, step-by-step problem solving for common printing problems, printer status information, and printer functions, such as printing test pages and aligning print cartridges.

The four tabs in the Toolbox include:

- How Do I?** Step-by-step instructions for basic printing tasks.
- Troubleshoot** Assistance for solving problems.
- Printer Service** Automated diagnostic and maintenance procedures.
- Printer Status** Provides printer status and ink level information .

Click here  to start the HP 2000C Toolbox.



Change Print Settings



You can change the print settings for the document you are currently printing, or you can change the print settings that apply to printing all documents.

Click here  for a tip about changing print settings.



[Change Print Settings for the Current Document](#)



[Change Print Settings for all Documents](#)



A tip for changing print settings

You will rarely need to specify settings in the HP Print Settings dialog box because the most common print settings are handled by the printer software or by HP ColorSmart II technology. However, you will need to specify settings when you print on HP special paper or when you use special print options (such as Grayscale Printing).

Change Print Settings for the Current Document

STEP 1 OF 3

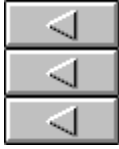

- 1 Open the document you want to print, and on the **File** menu, click **Print** or **Print Setup**.

Note: The menu or button choices for displaying the HP print settings dialog box will be different depending on the program and the Windows operating system you are using.



Change Print Settings for the Current Document

STEP 2 OF 3

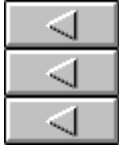

2 Click **Printer**, **Setup**, **Properties**, or **Options**.

Note: The command to change print settings may be different depending on the program and the operating system you are using.



Change Print Settings for the Current Document

STEP 3 OF 3

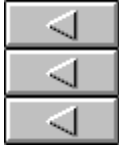

- 3 After you reach the HP print settings dialog box, you can select various print settings. These settings will apply to any document you print from a program before closing the program. When you have finished selecting print settings, click **OK**, and then print your document.



Build Tag Spacer for Win31

Change Print Settings for All Documents

STEP 1 OF 2

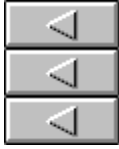

1 Click here  to open the Control Panel, and then double-click **Printers**.

-or-

In the Main program group, double-click **Control Panel**, and then double-click **Printers**.



Build Tag Spacer for Win31

Change Print Settings for All Documents

STEP 2 OF 2

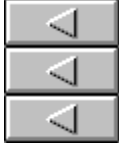

- 2 Select your printer in the **Installed Printers** list, and then click **Setup**. Any changes you make in the HP print settings dialog box become default print settings for all documents.



Build Tag Spacer for Win31

Select the Printer as the Default Printer

STEP 1 OF 2

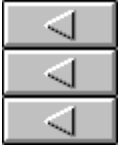

1 Click here  to open the Control Panel, and then double-click **Printers**.

-or-

In the Main program group, double-click **Control Panel**, and then double-click **Printers**.



Build Tag Spacer for Win31

Select the Printer as the Default Printer

STEP 2 OF 2

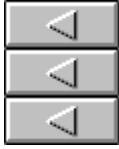

- 2 Select the HP 2000C Series printer from the **Installed Printers** list, then click **Set As Default Printer**. All print jobs will now print to the HP 2000C Series printer, unless you select a different printer from the print dialog box of a program.



Build Tag Spacer

Replace Ink Cartridges

STEP 1 OF 5

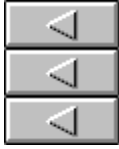

Note: [HP No.10 Ink Cartridges](#) are the correct replacement type for your HP 2000C printer.

1 Open the ink cartridge door.

Note: Do not remove an ink cartridge until you are ready to replace it. If one ink cartridge is missing or empty, the printer will not print until the ink cartridge is replaced.

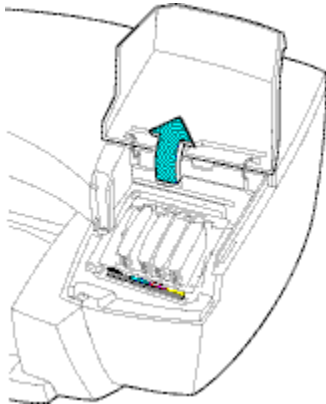

Replace Ink Cartridges

STEP 2 OF 5

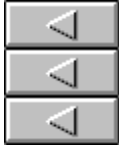

- 2 Grasp the top of the ink cartridge and remove it from the slot.

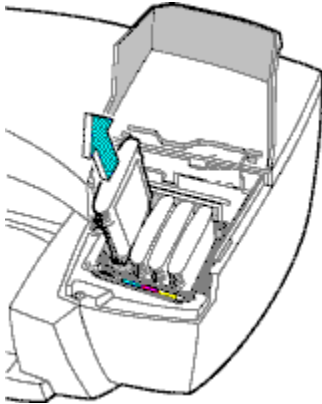

Replace Ink Cartridges

STEP 3 OF 5

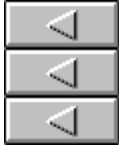

3 Remove the new ink cartridge from its package.

Note: To get the best print quality, make sure the ink cartridges are at room temperature before you install them.



Replace Ink Cartridges

STEP 4 OF 5

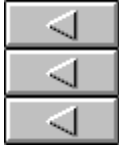

- 4 Match the color of the ink cartridge to the color of the slot in the printer, and firmly insert the ink cartridge into the slot. Each ink cartridge slot is designed so that only the correct ink cartridge will fit.

Note: If the ink cartridge does not fit easily, check that you are inserting the ink cartridge into the correct slot.

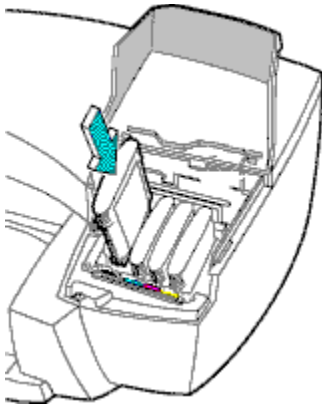

Replace Ink Cartridges

STEP 5 OF 5

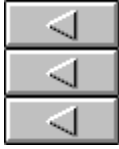

- 5 Repeat steps 2 through 4 to replace any other ink cartridges, and then close the ink cartridge door.

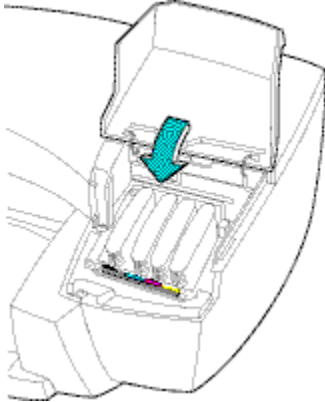

Note: If the Attention light was flashing before you began, then inserting the new ink cartridge should cause the light to stop flashing. If the Attention light is still flashing after inserting the ink cartridge, check to see that you have inserted the correct color and type of ink cartridge, then try reinstalling the ink cartridge. [Click here](#)

if the printer does not resume normal operation after following these steps.

Replace Printheads

STEP 1 OF 11

Note: [HP No.10 Printheads](#) are the correct replacement type for your HP 2000C printer. Printheads should not be replaced unless popup messages or the online Troubleshooting guide indicate that replacement is needed.

- 1 Make sure the power is on and then open the ink cartridge door.

Note: The power must be on in order to access the printheads.

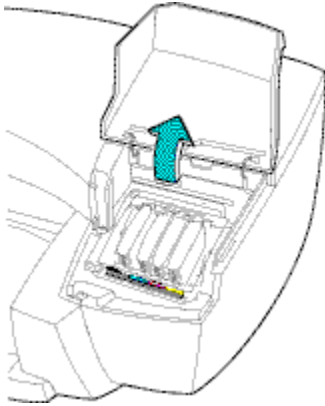

Replace Printheads

STEP 2 OF 11

- 2 Lift and remove the printhead access cover from the printer and set it aside.

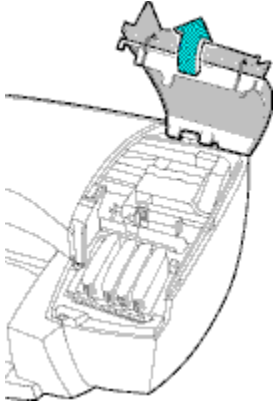

Replace Printheads

STEP 3 OF 11

- 3 Pull the purple printhead latch toward you until it rests upside down on top of the ink cartridges.

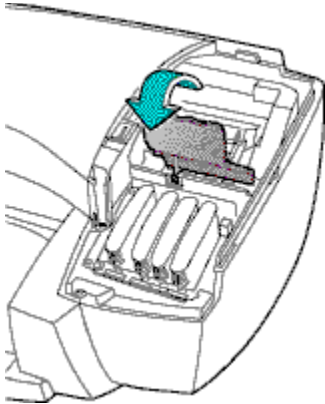

Replace Printheads

STEP 4 OF 11

- 4 Raise the purple printhead latch to reveal the printhead area.

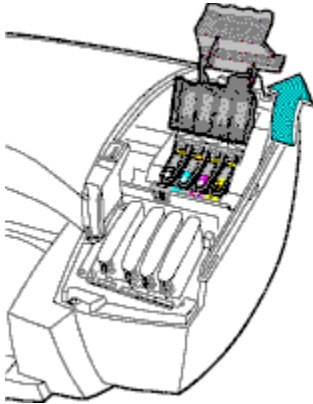

Replace Printheads

STEP 5 OF 11

- 5 Each printhead has a tab at the front which is connected to a handle. Using the tab, raise the handle and pull the printhead out of the socket.

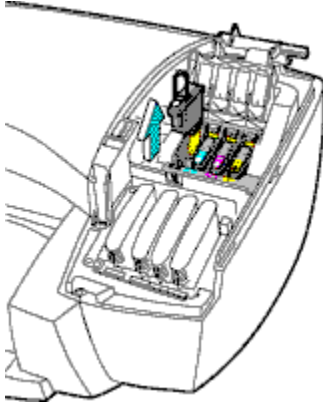

Replace Printheads

STEP 6 OF 11

- 6 Remove the printhead from its package, and gently remove the tape covering the ink nozzles and electrical contacts. Be careful not to touch the copper-colored contacts.

Warning: Do not leave the new printhead out of the printhead socket for too long. The microscopic nozzles can become damaged or clogged if left out of the printhead socket for too long.

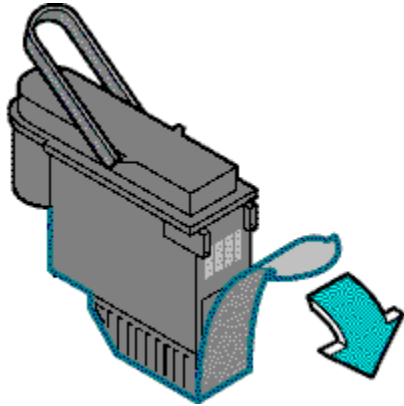

Replace Printheads

STEP 7 OF 11

- 7 Match the color on the printhead to the same color socket in the printer. Holding the printhead by the handle, align the arrow on the printhead with the arrow on the printer socket and lower the printhead into the socket.

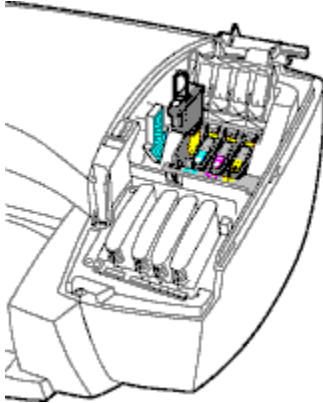

Replace Printheads

STEP 8 OF 11

- 8 Lower the purple printhead latch down so it covers the printheads and the edges of the ink cartridges.

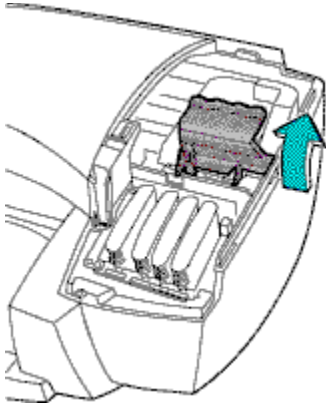

Replace Printheads

STEP 9 OF 11

- 9 Fold back the purple printhead latch until it lies flat. Make sure the hook on the latch is secured inside the purple carriage lock.

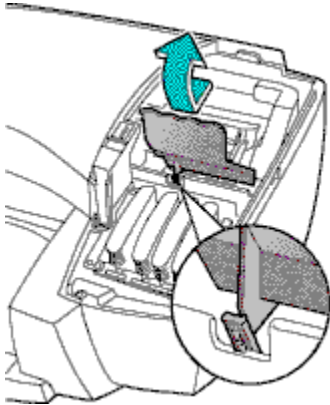

Replace Printheads

STEP 10 OF 11

- 10 Position the printhead access cover over the printer. Rest the two tabs on the back edge of the cover on either side of the tab on the back of the printer.

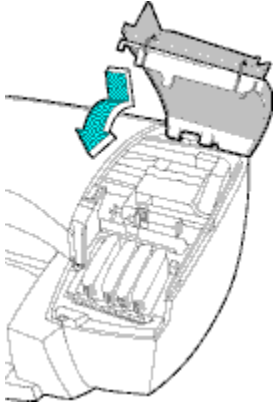

Replace Printheads

STEP 11 OF 11

11 Lower the printhead access cover until it snaps into place, and then close the ink cartridge door.

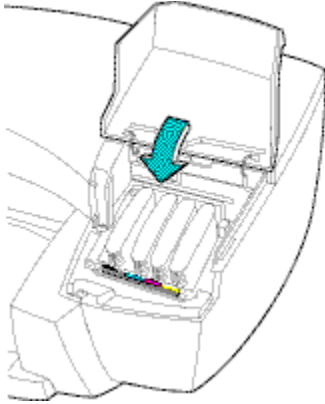

Close the Printhead Latch and Printhead Access Cover

STEP 1 OF 6

- 1 Make sure the power is on and then open the ink cartridge door.
-
-

Close the Printhead Latch and Printhead Access Cover

STEP 2 OF 6

- 2 Lift and remove the printhead access cover from the printer and set it aside.

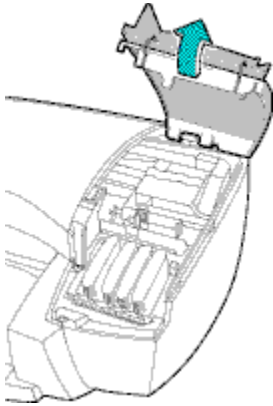

Close the Printhead Latch and Printhead Access Cover

STEP 3 OF 6

- 3 Pull the purple printhead latch toward you until it rests upside down on top of the ink cartridges.

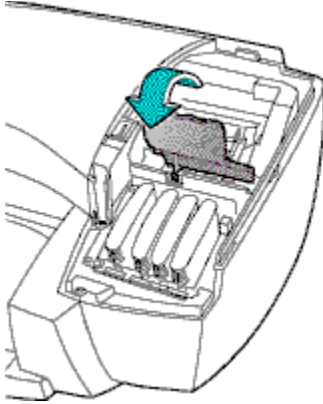

Close the Printhead Latch and Printhead Access Cover

STEP 4 OF 6

- 4 Fold back the latch until it lies flat. Make sure the hook on the latch is secured inside the purple carriage lock.

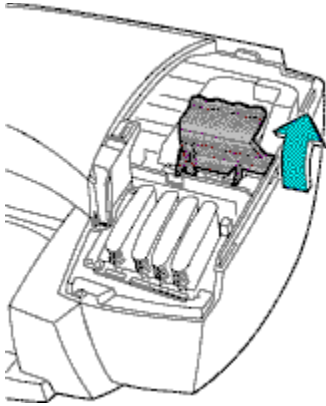

Close the Printhead Latch and Printhead Access Cover

STEP 5 OF 6

- 5 Position the Printhead Access Cover over the printer. Rest the two tabs on the back edge of the cover on either side of the tab on the back of the printer.

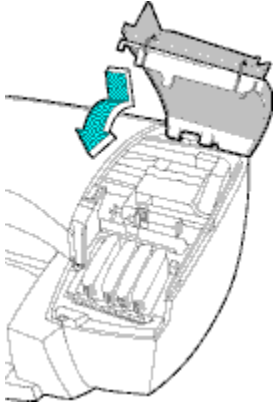

Close the Printhead Latch and Printhead Access Cover

STEP 6 OF 6

- 6 Lower the printhead access cover until it snaps into place, and then close the ink cartridge door.

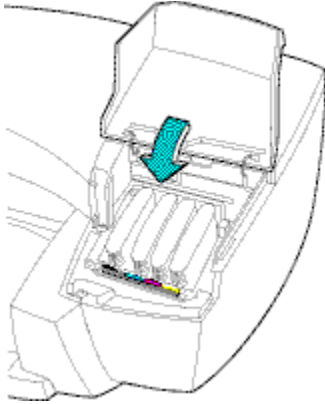

Print on a Variety of Paper Types and Sizes

[Choose the right paper to use](#)

[Print on standard office paper](#)

[Print transparencies or slides](#)

[Print on HP premium papers](#)

[Print labels](#)

[Print on custom-size paper](#)

[Print envelopes](#)

[Print postcards](#)

Select the Right Supplies for the Printer

Your HP 2000C printer uses [HP No.10 Ink Cartridges and Printheads](#) which are specially designed to work with the printer.

Your HP 2000C Printer provides outstanding print quality and professional results when you use ink products and supplies that are specially designed by HP.

[Click here](#)

for instructions on replacing ink cartridges.

[Click here](#)

for instructions on replacing printheads.

Special HP Paper Supplies

These papers produce outstanding results for printing that requires the highest quality. Click on any of the following paper types for more information.

[HP Bright White Paper](#)

[HP Transparency Film](#)

[HP Rapid-Dry Transparencies](#)

[HP Premium InkJet Paper](#)

[HP Premium Photo Paper](#)

[HP Deluxe Photo Paper](#)

[Labels](#)

[HP Greeting Card Paper](#)

[HP Premium Heavyweight Paper](#)

HP Bright White Paper

Use HP Bright White Paper for everyday printing to produce high-contrast colors and sharp text. This paper is perfect for newsletters, reports, proposals and flyers, and can be printed on both sides without showing through.

HP Transparency Film

HP Premium Transparency Film has been specially designed to get the best results from your printer automatically. The printer is designed to detect HP Premium Transparency Film and automatically adjust print settings to give you great looking slides. HP Premium Transparency Film works with HP special inks to give you crisp images and text and the fastest drying times.

HP Rapid-Dry Transparencies

HP Rapid-Dry Transparencies are specially designed for faster printing of transparency slides. When you need great quality slides in a hurry, choose HP Rapid-Dry Transparencies.

HP Premium InkJet Paper

Use HP Premium InkJet Paper for printing presentations, final copies of important documents, charts, and graphs. HP Premium InkJet Paper gives you sharper, brighter colors and superior black text compared to plain paper.

HP Premium Photo Paper

Use HP Premium Photo Paper for printing photos with a glossy finish.

HP Deluxe Photo Paper

For the best fleshtones and true-to-life landscape colors, use HP Deluxe Photo Paper. Kodak Image Enhancements will be used only when HP Deluxe Photo Paper is selected in the print settings dialog box. HP Deluxe Photo Paper and Kodak Image Enhancements are specifically designed by HP and Kodak for your HP 2000C printer.

Labels

For best results when printing labels, use labels specifically designed for inkjet (or DeskJet) printers, such as Avery InkJet Labels. Using other types of labels can cause ink drying problems or serious paper jams that require service. To avoid problems, be sure to use inkjet labels that are not folded, curled, wrinkled, partially used, or more than 2 years old.

HP Greeting Card Paper

Use HP Greeting Card Paper to create colorful cards, invitations, and notes for all occasions. HP Greeting Card Paper is pre-scored so that your cards fold precisely into quarters, and its special coating prevents smudging or smearing. Custom envelopes are included. You can also special-order card stock that has preprinted borders and designs for every occasion.

HP Premium Heavyweight Paper

HP Premium Heavyweight Paper is the perfect choice for printing cards, signs, report covers, certificates, or any print job that needs heavy, durable paper.

Print Transparencies or Slides

STEP 1 OF 2

1 Load transparency film in the paper tray with the rough side down and the adhesive strip forward.

Note: HP Premium Transparency Film has been specially designed to get the best results from your printer automatically! The printer is designed to detect HP Premium Transparency Film and automatically adjust print settings to give you great looking slides.

Print Transparencies or Slides

STEP 2 OF 2

- 2 If you intend to write on your transparencies, click the **Features** tab in the [HP print settings dialog box](#) and select **Flip Horizontal**.

When you use your transparencies, place them print-side down on the overhead projector and write on the back. Because **Flip Horizontal** reverses the image, the transparencies will look correct when they are placed face down.

Print on Envelopes

You can print one envelope at a time using the single-envelope slot, or up to 15 envelopes using the IN Tray. Select the method you want to use:

[Print a single envelope](#)

[Print a stack of envelopes \(up to 15 at once\)](#)

Click here

for tips about choosing envelopes.

Print on a Single Envelope

STEP 1 OF 2

- 1 With the flap up and to the right, slide the envelope evenly into the Single-Envelope Slot until the envelope stops.
-
-

Print on a Single Envelope

STEP 2 OF 2

- 2 In the [HP print settings dialog box](#), click the **Setup** tab. In the **Paper Size** box, select the size of envelope you are using, and then click **OK**. Print your envelope.

Click here

for information about changing print settings.

Print on a Stack of Envelopes

STEP 1 OF 4

- 1** Remove all paper from the IN Tray.
-

Print on a Stack of Envelopes

STEP 2 OF 4

- 2 With the flaps up and to the right, slide the envelopes evenly into the IN Tray until they stop.

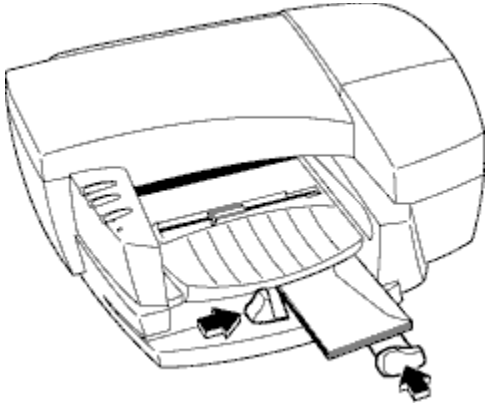

Print on a Stack of Envelopes

STEP 3 OF 4

- 3** Slide the paper width and length adjusters snugly against the edges of the stack of envelopes.
-

Print on a Stack of Envelopes

STEP 4 OF 4

- 4 In the [HP print settings dialog box](#), click the **Setup** tab. In the **Paper Size** box, select the size of envelope you are using, and then click **OK**. Print your envelope.

[Click here](#)

for information about changing print settings.

Tips For Selecting and Using Envelopes

You can either print envelopes one at a time from the Single-Envelope Slot or up to 15 at a time using the IN Tray.

- Use high-quality envelopes that are thin and sharply creased.
 - Do not use envelopes that are shiny or embossed, or that have clasps or windows.
-

Print on HP Premium Papers

STEP 1 OF 3

1 Insert HP Premium InkJet or HP Photo Paper in the IN Tray.

Note: Use HP Premium InkJet or Photo Papers, which are specifically designed to work with your HP printers, or use other premium paper designed to work with inkjet printers.

Print on HP Premium Papers

STEP 2 OF 3

2 In the [HP print settings dialog box](#), click the **Setup** tab. In the **Paper Type** box, select the type of paper you are using:

- **HP Premium Photo Paper** or **HP Deluxe Photo Paper**, designed to produce the highest-quality printouts with standard print cartridges
 - **HP Premium InkJet Paper**, designed to give you higher quality black and color output than plain paper
-

Print on HP Premium Papers

STEP 3 OF 3

3 In the **Print Quality** box, select **Best**, and then click **OK**. Print your document.

Print Photographs

STEP 1 OF 3

- 1 In the [HP print settings dialog box](#), click the **Setup** tab. In the **Paper Type** box, click **HP Deluxe Photo Paper**.

[Click here](#)

for information about changing print settings.

Note: For the best fleshtones and true-to-life landscape colors, use HP Deluxe Photo Paper. Kodak Image Enhancements will be used only when HP Deluxe Photo Paper is selected in the HP print settings dialog box. HP Deluxe Photo Paper and Kodak Image Enhancements are specifically designed by HP and Kodak for your HP 2000C printer.

Includes

Kodak

Image
Enhancements

Print Photographs

STEP 2 OF 3

2 In the **Print Quality** box, make sure **Best** is selected, and then click **OK**.

Print Photographs

STEP 3 OF 3

- 3 Insert the HP Deluxe Photo Paper, print-side down, into the IN Tray, and then print your photograph.
-

Print Labels

STEP 1 OF 3

[Click here](#)

for a tip on creating labels.

1 Fan the stack of labels to make sure none of the pages are sticking together.

Note: For best results when printing labels, use labels specifically designed for inkjet (or DeskJet) printers, such as Avery InkJet Labels. Using other types of labels can cause ink drying problems or serious paper jams that require service. To avoid problems, be sure to use inkjet labels that are not folded, curled, wrinkled, partially used, or more than 2 years old.

Print Labels

STEP 2 OF 3

- 2** Slide the paper length and width adjusters out to their fully extended positions. Slide a stack of labels, print-side down, along the right edge of the IN Tray on top of approximately 25 sheets of paper.
-

Print Labels

STEP 3 OF 3

3 Slide the paper width and length adjusters snugly against the edges of the stack of labels. Print your labels.

Tip Before printing on a sheet of labels, first print on a plain sheet of paper. Then, hold the paper up against a blank sheet of labels and check that the alignment is correct.

A tip on creating labels

Most of the popular word-processing programs, such as Microsoft Word or WordPerfect, offer an option to use predefined label templates. This option automatically formats the standard label types available from label manufacturers such as Avery or 3M by referencing their unique order numbers. For information on using a label template, see the documentation for your word processing program.

Print on Custom-Size Paper

STEP 1 OF 4

- 1 In the [HP print settings dialog box](#), click the **Setup** tab. In the **Paper Size** box, select **Custom**.

The **Custom Paper Size** dialog box appears.

[Click here](#)

for information about changing print settings.

Print on Custom-Size Paper

STEP 2 OF 4

2 Under **Paper Size**, type values in the **Width** and **Length** boxes, and then click **OK**.

Note: The paper width must be between 3.0 inches and 8.5 inches (76.2 mm and 215.9 mm); the paper length must be between 5.0 inches and 14 inches (127 mm and 355.6 mm).

Print on Custom-Size Paper

STEP 3 OF 4

- 3 With the print side down, insert the stack of custom-size paper along the right edge of the IN Tray. The stack should not be higher than the level indicator mark on the right side of the IN Tray. Too much paper can prevent the printer from picking up paper from the stack.
-

Print on Custom-Size Paper

STEP 4 OF 4

- 4 Slide the length and width adjusters to fit snugly against the edges of the stack. This keeps the paper straight as it feeds through the printer. Print your document.
-

Print Postcards

STEP 1 OF 3

- 1 With the print side down, insert the stack of postcards along the right edge of the IN Tray. The stack should not be higher than the level indicator mark on the right side of the IN Tray. Too much paper can prevent the printer from picking up paper from the stack.
-

Print Postcards

STEP 2 OF 3

- 2** Slide the length and width adjusters to fit snugly against the edges of the stack. This keeps the paper straight as it feeds through the printer.
-

Print Postcards

STEP 3 OF 3

- 3 In the [HP print settings dialog box](#), click the **Setup** tab. In the **Paper Size** box, select the size of the postcards you are printing, and then click **OK**.

-or-

Select **Custom** if none of the sizes match the postcard size you are printing. Print your postcards.

[Click here](#)

for information about changing print settings.

[Click here](#)

for information about printing on custom-sized paper.

Print on Standard Office Paper

STEP 1 OF 3

- 1** With the print side down, insert the stack of paper along the right edge of the IN Tray. The stack should not be higher than the level indicator mark on the right side of the IN Tray. Too much paper can prevent the printer from picking up paper from the stack.
-
-

Print on Standard Office Paper

STEP 2 OF 3

- 2** Slide the length and width adjusters to fit snugly against the edges of the stack. This keeps the paper straight as it feeds through the printer.
-
-

Print on Standard Office Paper

STEP 3 OF 3

- 3 In the [HP print settings dialog box](#), make any necessary changes to print settings, such as print quality or orientation, and then click **OK**. Print your document.

Click here

for information about changing print settings.

Tips for Selecting and Using Paper and Other Media

Choosing the right paper is important for high quality printing. Choose HP paper products, which have been designed to work best with your printer, and offer reliability as well as quality.

- If you are purchasing large quantities of a certain type of paper that is not made or recommended by HP, test a small sample to make sure it is compatible with the printer.
- Always use paper (and other media) that conforms with the specifications listed under "Recommended Media Weight" and "Media Size" in the Printer Specifications section of the user guide.

Once you have selected your paper you should always use proper loading procedures and techniques to avoid paper jam problems.

- Make sure the right edge of the paper stack is against the right edge of the IN Tray. [Click here](#)

for information about loading paper (and other media) in the IN Tray.

- Insert paper print-side down, as shown on the package. This includes all paper, cards, envelopes, labels, and transparencies loaded into the IN Tray.
 - Do not use paper that is damaged, curled, or wrinkled.
 - Do not use paper with cutouts or perforations, or paper that is heavily textured or embossed.
 - Do not use multiple-part forms.
-

Print On Both Sides of the Page

STEP 1 OF 4

- 1 In the [HP print settings dialog box](#), click the **Features** tab. In the **Two-sided Printing** box, select either **Book** (recommended for most standard jobs) or **Tablet**, and then click **OK**.

[Click here](#)

for information about changing print settings.

Print On Both Sides of the Page

STEP 2 OF 4

- 2** Make sure the IN Tray contains an adequate supply of paper, and the OUT Tray is empty. Then print your document. Do not remove any of the printed pages during this stage of the print job.
-

Print On Both Sides of the Page

STEP 3 OF 4

- 3** After all of the odd-numbered pages print, a screen appears with instructions for reinserting the paper to print the even-numbered pages. Follow the instructions on the screen.
-

Print On Both Sides of the Page

STEP 4 OF 4

- 4 When the paper is ready, click **Continue** to finish printing your two-sided document.

The even-numbered pages will print on the reverse side of the odd-numbered pages.

Note: After you are finished, be sure to change the **Two-sided Printing** option back to **None** in the [HP print settings dialog box](#).

Printing on a network

If your computer is on a network, you can connect the HP 2000C printer to your network. The recommended way to attach your printer to a network is by using an external print server, such as an HP JetDirect print server. Another option is to connect the printer to one of the computers on the network and then share the printer using the network sharing options provided through Microsoft Windows.

Network-Connect

In a network-connect configuration, the printer connects to the network using a direct attachment to an external print server, such as an HP JetDirect EX-300, EX Plus, 150X, or EX Plus3 print server. This configuration provides the best network printer performance, flexibility in printer location, and enhanced printer status information.

Printer status information is a key reason for choosing this type of network connection. The HP 2000C printer is designed to communicate a full range of messages that inform users about ink cartridge levels, ink cartridge and printhead conditions, paper conditions, paper jams, and printing system conditions.

Locally shared

In a locally shared configuration, the printer is connected directly to the parallel port of a computer on the network. The printer can be shared by others on the network through a Microsoft Windows network printer connection.

The advantages of a locally shared printer are easy installation and minimal cost, since no additional hardware or software is needed.

The disadvantages of a locally shared printer are limited printers status information for network users, limited flexibility in printer location, and possibly slower printer and host computer performance. Depending on priority settings and number of users on the network, the host computer may slow down while handling print jobs and other print jobs may be delayed for network users. If the host computer is turned off or restarted, print jobs may be lost or not printed.

Install the Optional Accessory Paper Tray

STEP 1 OF 3

- 1 Place the optional Accessory Paper Tray where you want to place the printer.
-
-

Install the Optional Accessory Paper Tray

STEP 2 OF 3

- 2 Pick up the printer and set it down on top of the tray, aligning the pegs on the tray with the corresponding holes in the printer.

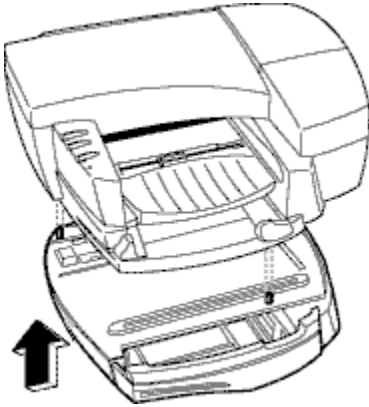

Install the Optional Accessory Paper Tray

STEP 3 OF 3

- 3 Check the printer and the Accessory Paper Tray to make sure they are properly placed.

Note: When bidirectional communication exists between the printer and computer, the printer software will automatically update to include the optional Accessory Paper Tray as a selectable paper tray.

[Click here](#)

for instructions on selecting a paper tray.

Print from DOS Software Programs

Printer drivers are supplied by the manufacturers of DOS software programs. The following table lists some commonly used DOS software programs and their recommended printer drivers. If you do not use any of these programs, contact the manufacturer of the software program you are using to obtain a compatible printer driver.

DOS Software Program	Version	Recommended Printer Driver
WordPerfect	5.1, 5.1+, 6x	HP DeskJet 600, 660C or 850C
Harvard Graphics	3.0	HP DeskJet 540
Lotus 1-2-3	2x, 3x, 4.0	HP DeskJet 540
MS Word	5.5, 6.0	HP DeskJet 560C

Troubleshoot a Printing Problem

If there is a problem with the printer, and bidirectional communication is working properly between the printer and your computer, an error message will appear on your computer screen to help you resolve the problem. Follow the onscreen instructions to resolve the problem.

However, if bidirectional communication does not exist or is disabled, you can use the online Help troubleshooter in the HP 2000C Toolbox.

Click [here](#)

to start the HP 2000C Toolbox.

Once the HP 2000C Toolbox opens, select the **Troubleshoot** tab and follow the instructions on the screen to troubleshoot your printing problem.

Increase Printer Performance

Many factors affect printing speed and overall performance. In some cases, you can adjust settings or change your printing environment in order to increase the speed and quality of your print jobs. The following is a list of factors that affect printing performance.

- The amount of RAM in your computer.
 - The available hard disk space in your computer.
 - The processing speed of your computer.
 - Which printer is selected from your software program. Make sure the HP 2000C Series printer is selected.
 - The size and complexity of the file you are printing.
 - The number of software programs or documents you have open at the time you are trying to print.
 - The print settings in the printer driver that determine the print quality of your document-Best, Normal, and EconoFast.
 - Text or images that are printing require dense ink coverage.
-

Supported Languages and Regional Fonts

You only need to install the one file that supports your particular language. If you are uncertain which language is included in your printer, check the serial number label on the back of the printer for one of the following codes:

ARB = Arabic

CYR = Cyrillic

GRK = Greek

HBR = Hebrew

LTV = Latvian

LIT = Lithuanian

THA = Thai

Clear a Paper Jam inside the printer

STEP 1 OF 7

- 1** Remove any paper from the IN Tray and OUT Tray.
-

Clear a Paper Jam inside the printer

STEP 2 OF 7

- 2 Lift the OUT Tray upward and pull it sharply toward you.

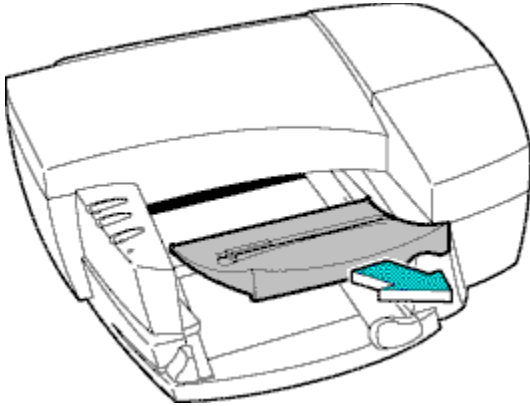

Clear a Paper Jam inside the printer

STEP 3 OF 7

- 3** Locate the paper jammed inside the printer, and pull firmly to remove it.
-

Clear a Paper Jam inside the printer

STEP 4 OF 7

- 4** Make sure all scraps of paper are removed from the paper path.
-

Clear a Paper Jam inside the printer

STEP 5 OF 7

- 5** Look for any other obstructions in the paper path.
-

Clear a Paper Jam inside the printer

STEP 6 OF 7

- 6 Replace the OUT Tray by sliding it along the panels just above the IN Tray. When you hear both sides of the tray click, it is locked into place.

Press the Resume (

) button on the printer to resume printing.

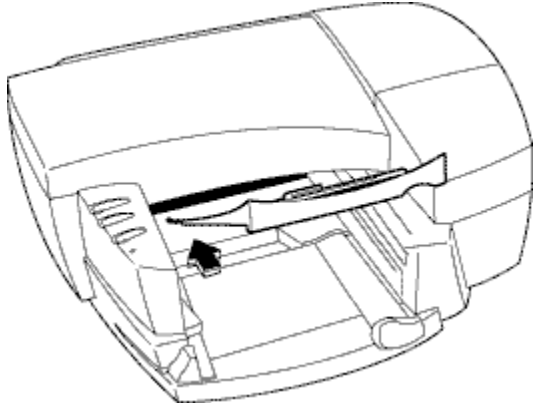

Clear a Paper Jam inside the printer

STEP 7 OF 7

- 7 If the problem recurs frequently, or you cannot locate the location of the paper jam, click here [for information about contacting the HP Customer Support Center.](#)
-

Clear a Paper Jam in the Optional Accessory Paper Tray

STEP 1 OF 4

- 1 Lift the printer off of the Accessory Paper Tray and set it aside.

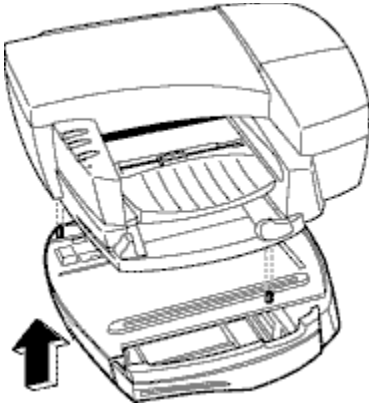

Clear a Paper Jam in the Optional Accessory Paper Tray

STEP 2 OF 4

- 2 Remove any paper from the paper feed slot.
-

Clear a Paper Jam in the Optional Accessory Paper Tray

STEP 3 OF 4

- 3 Remove the paper drawer from the optional Accessory Paper Tray. Make sure all scraps of paper are removed from the paper path.
-

Clear a Paper Jam in the Optional Accessory Paper Tray

STEP 4 OF 4

- 4 Reload the paper into the Accessory Paper Tray, and place the printer back on top of the Accessory Paper Tray.
Press the Resume () button on the printer to resume printing.
-

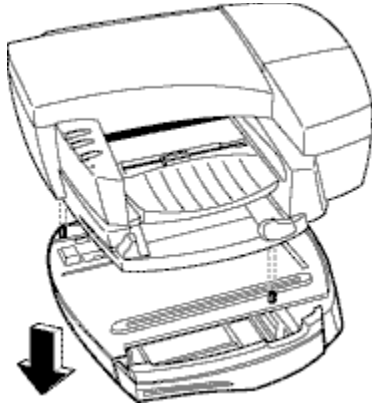

Build Tag Spacer for Win31

Turn off spooling

STEP 1 OF 2

1 [Click here](#)

to open the Control Panel, and then double-click **Printers**.

-or-

In the Main program group, double-click **Control Panel**, and then double-click **Printers**.

Build Tag Spacer for Win31

Turn off spooling

STEP 2 OF 2

- 2 Click **Use Print Manager** so that it is not selected, then click **OK**. Future print jobs will be printed directly to the printer without spooling the job first.
-

Build Tag Spacer for Win31

Port Configuration

STEP 1 OF 3

1 [Click here](#)

to open the Control Panel, and then double-click **Printers**.

-or-

In the Main program group, double-click **Control Panel**, and then double-click **Printers**.

Build Tag Spacer for Win31

Port Configuration

STEP 2 OF 3

2 Click **Connect...**

Build Tag Spacer for Win31

Port Configuration

STEP 3 OF 3

3 Select **Fast Printing Direct to Port**, and click **OK**.

Bidirectional Communication

Bidirectional communication exists when your HP 2000C Series is connected to your computer with an I-EEE-compliant parallel printer cable, enabling the printer to communicate with the computer. Through bidirectional communication, you will receive messages regarding printing problems or status messages, such as notification that ink cartridges are low or out, or that printheads are not installed correctly.

Contact HP

There are several options for getting assistance directly from HP. Click one of the following for more information:

[Support and updates on the worldwide web](#)

[Help from the HP Support Center](#)

[Help from the HP FIRST Fax Program](#)

Support and updates on the worldwide web

The fastest and most up-to-date technical support for your printer is provided by HP at:

<http://HP2000C.com/>

This web site provides you with the latest drivers, information, and the most recent worldwide support telephone numbers.

Help from the HP Support Center

Your printer comes with a 90-day warranty for telephone support and a 1-year warranty for repair. This means you will receive free telephone support from HP if you have owned your printer for 90 days or less, and free repairs from HP if you have owned your printer for 1-year or less.

Information on calling HP:

In the U.S. and Canada

In Europe

In Latin America

In Asia/Pacific

In Africa or the Middle East

In the U.S. and Canada

During the Warranty Period

If you have owned your printer for 90 days or less and need technical support OR your printer needs repair and you have owned your printer for less than 1 year, click the option above.

After the Warranty Period

If you have owned your printer for more than 90 days and need technical support OR your printer needs repair and you have owned your printer for more than 1 year, click the option above.

During the Warranty Period

Note: Long distance charges may apply.

Please be at your computer when you call and have your printer service ID ready. To obtain your printer service ID, hold the Power (⏻) button down and click the Resume (⏪) button 5 times. A page will print out that shows the printer service ID. Ignore this step if the printer is unable to print.

Country	Telephone Number	Hours of Operation
U.S.		
Canada (English)	(208) 323-2551	M-F, 6am-10pm (MST) SAT, 9am-4pm (MST)
Canada (French)	(905) 206-4383	M-F, 6am-10pm (MST) SAT, 9am-4pm (MST)

After the Warranty Period

Click one of the following:

[U.S.](#)

[Canada \(English\)](#)

[Canada \(French\)](#)

After the Warranty Period - U.S.

Please be at your computer when you call and have your printer service ID ready. To obtain your printer service ID, hold the Power (⏻) button down and click the Resume (⏪) button 5 times. A page will print out that shows the printer service ID. Ignore this step if the printer is unable to print.

Telephone Number	Hours of Operation
(900) 555-1500	M-F, 6am-10pm (MST) SAT, 9am-4pm (MST)

You will be charged \$2.50 per minute up to a maximum of \$25. The charge will begin only when you are connected with a support technician. This fee will be charged to your Visa or MasterCard, so please have it available.

After the Warranty Period - Canada (English)

Please be at your computer when you call and have your printer service ID ready. To obtain your printer service ID, hold the Power (⏻) button down and click the Resume (⏪) button 5 times. A page will print out that shows the printer service ID. Ignore this step if the printer is unable to print.

Telephone Number

(800) 999-1148

Hours of Operation

M-F, 6am-10pm (MST)
SAT, 9am-4pm (MST)

The fee is \$25 per call. The charge will begin only when you are connected with a support technician. This fee will be charged to your Visa or MasterCard, so please have it available.

After the Warranty Period - Canada (French)

Please be at your computer when you call and have your printer service ID ready. To obtain your printer service ID, hold the Power (⏻) button down and click the Resume (⏪) button 5 times. A page will print out that shows the printer service ID. Ignore this step if the printer is unable to print.

Telephone Number

(800) 999-1148

Hours of Operation

M-F, 8:30am-5pm

The fee is \$25 per call. The charge will begin only when you are connected with a support technician. This fee will be charged to your Visa or MasterCard, so please have it available.

In Europe

Note: Long distance charges may apply.

Please be at your computer when you call and have your printer service ID ready. To obtain your printer service ID, hold the Power (⏻) button down and click the Resume (⏪) button 5 times. A page will print out that shows the printer service ID. Ignore this step if the printer is unable to print. All times below are Central European Time, unless otherwise noted.

) button 5 times. A page will print out that shows the printer service ID. Ignore this step if the printer is unable to print. All times below are Central European Time, unless otherwise noted.

Country	Telephone Number	Hours of Operation
Austria	06.60.63.86	M-F, 8:30am-6pm
Belgium (Dutch)	02.626.88.06	M-F, 8:30am-6pm
Belgium (French)	02.626.88.07	M-F, 8:30am-6pm
Czech Republic	42 (2) 471 7321	M-F, 8:30am-6pm
Denmark	3929.4099	M-F, 8:30am-6pm
English (non-UK)	+44.171.512.52.02	M-F, 8:30am-6pm
Finland	0203.47.288	M-F, 8:30am-6pm
France	01.43.62.34.34	M-F, 8:30am-6pm
Germany	0180.52.58.143	M-F, 8:30am-6pm
Hungary	36 (1) 252 4505	M-F, 8:30am-6pm
Ireland	01.662.5525	M-F, 8:30am-6pm
Italy	02.2.641.0350	M-F, 8:30am-6pm
Netherlands	020.606.87.51	M-F, 8:30am-6pm
Norway	22.11.6299	M-F, 8:30am-6pm
Poland	48.22.37.50.65	M-F, 8:30am-6pm
Portugal	01.441.7199	M-F, 8:30am-6pm
Russia	7095.923.50.01	M-F, 8:30am-6pm
Spain	90.23.21.123	M-F, 8:30am-6pm
Sweden	08.619.2170	M-F, 8:30am-6pm
Switzerland	08.48.80.11.11	M-F, 8:30am-6pm
Turkey	90.1.224.59.25	M-F, 8:30am-6pm
United Kingdom	0171.512.52.02	M-F, 8:30am-6pm
Other European Countries	+44.171.512.52.0	M-F, 8:30am-6pm

In Latin America

Note: Long distance charges may apply.

Please be at your computer when you call and have your printer service ID ready. To obtain your printer service ID, hold the Power (⏻) button down and click the Resume (⏪) button 5 times. A page will print out that shows the printer service ID. Ignore this step if the printer is unable to print.

Country	Telephone Number	Hours of Operation
Mexico	01800-22147	M-F, 9am-6pm
Mexico	01800-90529	M-F, 9am-6pm
Brazil	022-829-6612	M-F, 9am-6pm
Argentina	787-8080	M-F, 8:30am-7:30pm
Chile	800-360999	M-F, 9am-6pm

In Asia/Pacific

Note: Long distance charges may apply.

Please be at your computer when you call and have your printer service ID ready. To obtain your printer service ID, hold the Power (⏻) button down and click the Resume (⏪) button 5 times. A page will print out that shows the printer service ID. Ignore this step if the printer is unable to print.

Country	Telephone Number	Hours of Operation
Australia	(03) 9272-8000	M-F, 9am-5pm
Hong Kong	800-96-7729	M-F, 9am-6pm
India	+91-11-6826035	M-F, 9:30am-5:30pm
Indonesia	62-21-350-3408	M-F, 8:30am-5:30pm
Malaysia	03-2952566	M-F, 8:30am-5:30pm
New Zealand	(09) 356-6640	M-F, 9am-5pm
Philippines	632-867-3551	M-F, 8:30am-5:30pm
Singapore	2725300	M-F, 8:30am-5:30pm
Thailand	662-661-4011	M-F, 8:30am-5:30pm
Vietnam	84-8-823-4530	M-F, 8:30am-5:30pm

For all other regions or countries, please contact your local dealer for service and support.

In Africa or the Middle East

Note: Long distance charges may apply.

Please be at your computer when you call and have your printer service ID ready. To obtain your printer service ID, hold the Power (⏻) button down and click the Resume (⏪) button 5 times. A page will print out that shows the printer service ID. Ignore this step if the printer is unable to print.

Country	Telephone Number	Hours of Operation
Africa or Middle East	+41 22/780 71 11	M-F, 8:30am-6pm (Central European Time)

Help from the HP FIRST Fax Program

HP FIRST is a free service that allows you to get technical support documents via your fax machine. This program is available 24 hours a day, 7 days a week.

Country	Telephone Number
North America	
U.S. and Canada	(800) 333-1917
Europe	
Austria	0660.8128
Belgium (Dutch)	0800.11906
Belgium (French)	0800.17043
Denmark	800.10453
Finland	9800.13134
France	05.905900
Germany	0130810061
Italy	1678.59020
Netherlands	0800.22.2420
Norway	800.11319
Portugal	800.313342
Spain	900.993.123
Sweden	020.795.743
Switzerland (French)	0800.55.1526
Switzerland (German)	0800.55.1527
United Kingdom	0800.960271
Other European countries	+31.20.681.5792

HP No. 10 Ink Cartridge and Printheads



HP No.10 Ink Cartridges and HP No.10 Printheads are designed for use with the HP 2000C printer. Using genuine HP printing supplies guarantees clear, sharp results. Look for HP No.10 selection numbers wherever printer supplies are sold.



HP No.10 Ink Cartridges are long lasting, require no maintenance and are easily replaceable. They have built-in smart printing technology that allows the printer to monitor the ink level and condition of each ink cartridge. Ink levels can be viewed anytime from the HP 2000C Toolbox. Online messages are sent which inform you when it is time to replace an ink cartridge.

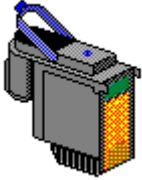

HP No.10 Printheads are designed for extended life and exceptional print speed and quality. Each printhead corresponds to one of the four ink colors, so be sure to look for the correct HP No.10 color printhead if replacement is ever needed. The four printheads have built-in smart printing technology to produce professional, high quality results that are consistent throughout the life of the ink cartridges and printheads.

HP No.10 Ink Cartridges and HP No.10 Printheads are JetSeries® products

HP print settings dialog box

The HP print settings dialog box allows you to access printer features from a software program, such as a word-processing or graphics program. You use the HP print settings dialog box to select print quality, page orientation, paper type, paper size, and ColorSmart options.

